



## **Splicebook**

Tips and tricks for expert splicing and choosing the appropriate rope.



## Dear Reader,

the Gleistein splicebook has been updated and is for the first time available in English. The content has been totally revised to give an overview of a variety of different splicing techniques.

This second edition combines our experience from more than 175 years of rope making and rigging with that of the cumulative knowledge of both traditional and modern experienced riggers in the field.

The “splice” is the optimal technical method of transferring a load to a length of rope. The splice’s efficiency also makes it the most economical method of rope termination, as its strength realisation is considerably greater than any knot, bend or hitch, regardless of the rope’s construction or material. In general, the higher the break load of a rope, the higher the price. In use a rope is only as good as its termination.

Every rope construction has it’s own characteristics, peculiarities and anomalies. The new Gleistein splicebook provides all the information that you need, in a simple form, to master the relevant splicing techniques. Whatever the application; whatever the material or construction; we are happy to share as much accumulated know – how as we can, because ...

... our concern is that things connect.

Yours

A handwritten signature in blue ink that reads 'Helmut Paul'. The signature is fluid and cursive, with the first name 'Helmut' being larger and more prominent than the last name 'Paul'.

Helmut Paul

# Our concern is that things connect



Our firm was founded in the year 1824 by Captain George Gleistein and his son. In 1999, Gleistein celebrates its 175th Birthday. The oldest industrial family enterprise in Bremen can look back on the exciting history of a company that has developed from an outfitter of large sailing vessels to a specialist manufacturer of many different modern and traditional textile constructions.



What has always counted at Gleistein is the use of existing skills and techniques to develop new ones. The combination of tradition and progress.



A rope is only as strong as its weakest point, which is invariably its end connection. Each construction, material and application has its optimum termination solution. We lay great emphasis on the spliceability of our ropes.

A competent splicer should have no difficulty in applying the techniques himself, but a visit to our rigging workshop or the premises of our agents or distributors worldwide should prove valuable to the skilled and unpractised splicer alike.

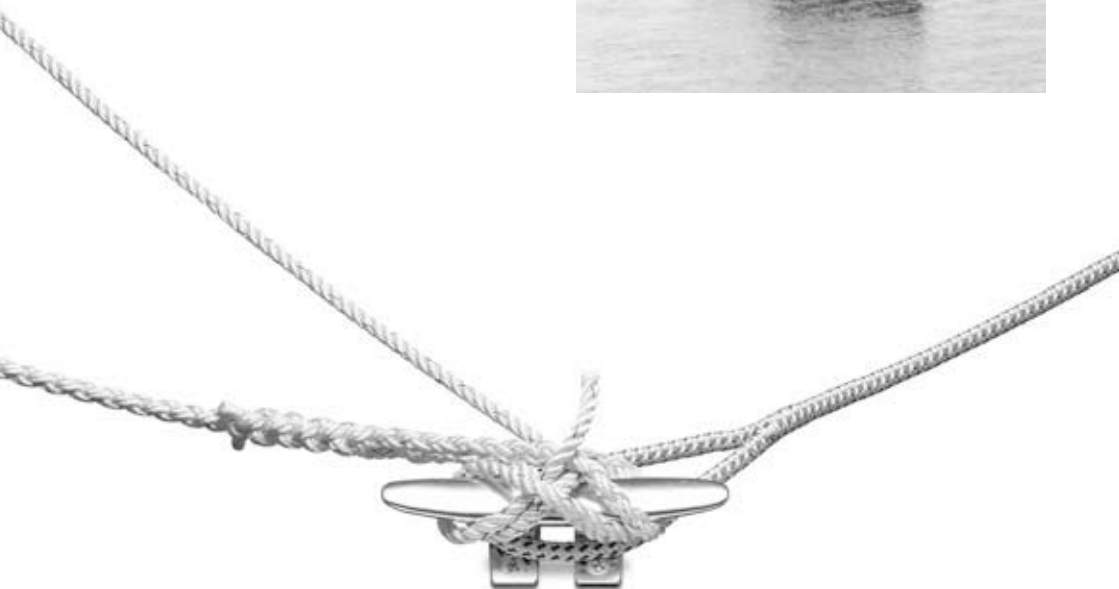







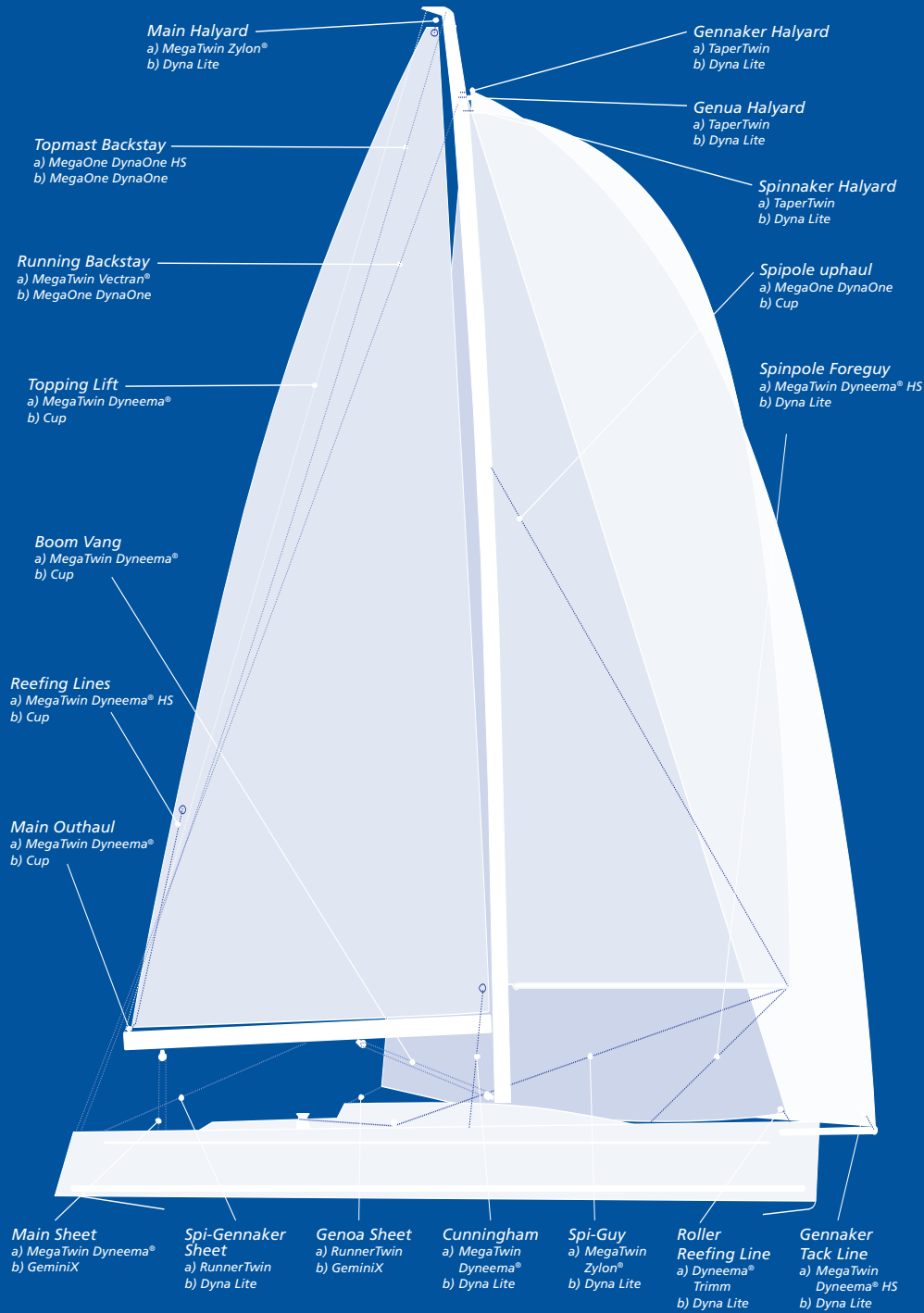



















With practice, patience and the instruction of this book, anybody can execute a reasonable splice. The right tools also help and these too we can supply.



# The right rope



# The course

	Splicing tools and accessories	Types and uses	Page 6
	<b>Multi-strand laid ropes</b> (e.g. Thempest)	 Eye-Splice	<b>Page 9</b> Page 10
	<b>Square Plaits</b> (e.g. Nylon Mooring Line)	 Eye-Splice	<b>Page 13</b> Page 14
	<b>Hollow Braids</b> (e.g. Polypropylene Hollow Braid)	 Eye-Splice	<b>Page 17</b> Page 18
	<b>Hollow Braids out of high modulus fibres</b> (e.g. Dyna One, Dyneema Trimm)	 End-to-End Splice	<b>Page 19</b>
	<b>Hollow Braids out of high modulus fibres</b> (e.g. Dyna One, Dyneema Trimm)	 Eye-Splice	<b>Page 21</b> Page 22
	<b>Hollow Braids out of high modulus fibres</b> (e.g. Dyna One, Dyneema Trimm)	 End-to-End Splice	<b>Page 24</b>
	<b>Double Braids</b> (e.g. Gemini X, Tasmania, Harkon, Standard, Bavaria, Dockline)	 Eye-Splice	<b>Page 25</b> Page 26
	<b>Double Braids</b> (e.g. Gemini X, Tasmania, Harkon, Standard, Bavaria, Dockline)	 End-to-End Splice	<b>Page 30</b>
	<b>Double Braids</b> (e.g. Gemini X, Tasmania, Harkon, Standard, Bavaria, Dockline)	 Back-Splice	<b>Page 34</b>
	<b>Braids with parallel fibre cores</b> (e.g. Cup, Cup Classic)	 Eye-Splice	<b>Page 37</b> Page 38
	<b>Braids with parallel twine cores</b> (e.g. Riviera)	 Eye-Splice	<b>Page 41</b> Page 42
	<b>Ropes with high modulus fibre cores</b> (e.g. Vectran, Dyneema, Dyneema Classic, Dynamix, Dyna Lite, Caribic Color)	 Eye-Splice Method 1	<b>Page 45</b>
	<b>Ropes with high modulus fibre cores</b> (e.g. Vectran, Dyneema, Dyneema Classic, Dynamix, Dyna Lite, Caribic Color)	 Eye-Splice Method 2	<b>Page 46</b> Page 50
	<b>Whippings</b>		<b>Page 52</b>

# Splicing tools and accessories

## Types and uses

The splicing tools for braided ropes are differentiated according to the task they have to fulfil. The splicing fid for twisted ropes forms openings beneath the strands, whereas the fid and pusher for a braided rope form tunnels in the braids, whilst at the same time, being measuring tools. All other rigging/splicing tools and accessories are identical.

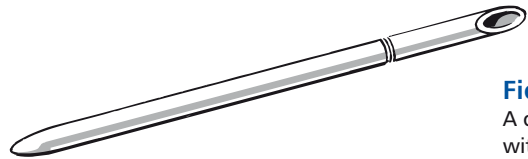

### Fid

A different size fid is needed for every rope with a diameter of 6 mm and over. The measurements are marked on the fid.

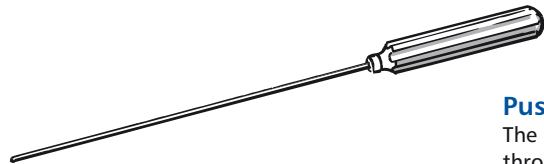

### Pusher

The pusher pushes the fid and rope end through the cover or core. There are two pusher sizes, one is for ropes up to 12 mm diameter, the larger pusher is for ropes over 12 mm diameter.



### Tape

Smooth adhesive tape is required to hold the rope ends together and prevent fraying.



### Markier-Stift

Felt-tippens are the most suitable.

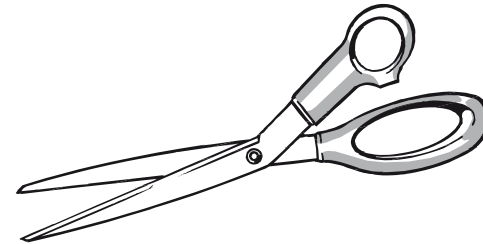

### Scissors

Very sharp scissors are required. All man made fibres quickly blunt scissors. Ceramic scissors are therefore better. Some riggers even use wire cutters, which have proven themselves well. A sharp knife may suffice with natural fibres.

### Rigging yarn, sewing needles, sailmakers palm:

Rigging yarns are waxed for easier working. The thickness of yarns should be appropriate to the respective rope diameter. Sewing needles are required with sewn whipping. The palm facilitates sewing through materials.

### Winch/Rigging Bench

It is sometimes useful to utilise a winch for the final closing of a splice with braided ropes. This ensures that the core of a rope over which the cover is to be milked, is under correct tension.



### Splicing Fid

Either a solid or hollow (swedish) fid which openings can be made between the strands of twisted ropes. Should be in every rigging kit.

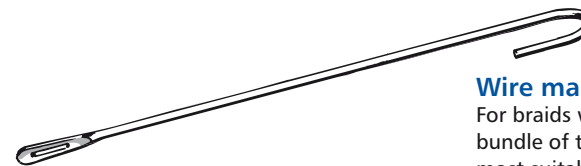

### Wire marline spike

For braids whose core consists of a twisted or a bundle of threads, the wire marline spike is the most suitable. The big eye of the spike is utilised to pull the core through the cover.



## Multi-strand laid ropes



Eye-Splice



### Construction and applications

The manufacture of ropes from twisted natural fibres was a technique used in ancient Egypt some 5.000 years ago.

Fibres twisted together make a yarn. Several of these yarns twisted together in opposing directions (to reduce the possibility of untwisting) produce a twine. Further twines form a strand. Three, four or six of these strands twisted together will form a laid rope. When the direction of twist alternates from stage to stage (i.e. from fibres, to yarns, to twines, to strands, to the final rope) the tendency of the rope to unlay, or untwist, is greatly reduced and the rope's stability and integrity enhanced.

The laid rope is used in a large variety of applications. On traditional vessels it is used as a mooring line, sheet or halyard. It is also widely used for many other specialised jobs such as towing, lashing or as security line. This multi purpose rope should always be used with a degree of caution, as laid ropes can have a tendency to kink or deform under certain loading conditions. A laid rope can be opened (with care) by using the opposite twist direction and the splicing technique for laid ropes takes advantage of this property.



# Eye-Splice

1.

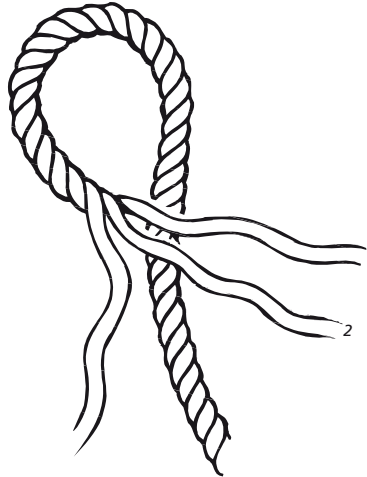

### Unlaying the rope end and determining the eye size

The three strands of the rope are unlaid about four turns. If the rope is loosely constructed one safeguards it from further unravelling by a temporary layer of tape. The strands and remaining rope should keep their original shape. The three strand ends are protected against further unravelling by heat-sealing, whipping or taping. The diagram shows how the size of an eye is determined. The middle strand (2) lies between strands (1) and (3), as well as lying on top of the rope.

2.

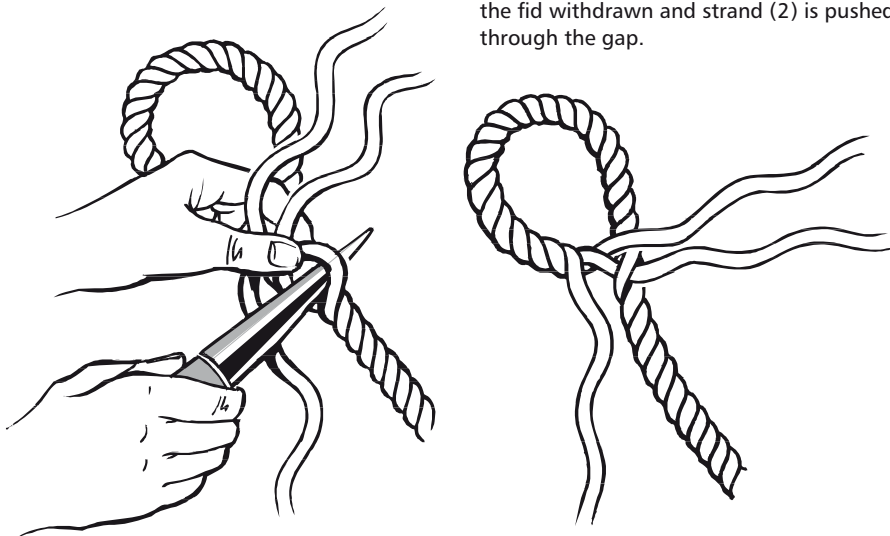

### Tucking through strand 2

The fid is used to create a gap under the uppermost strand. The gap is maintained, the fid withdrawn and strand (2) is pushed through the gap.

3.

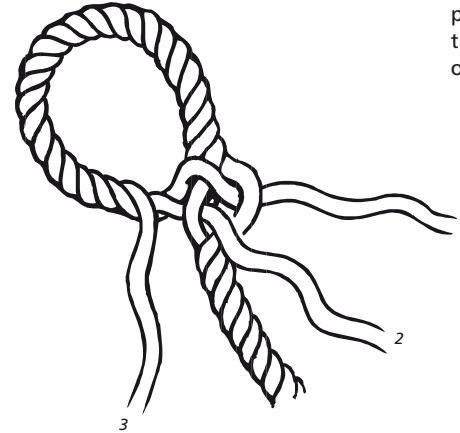

### Tucking through strand (1)

The next step is to splice strand (1). The splicing position is turned towards the body slightly and the same procedure as with strand (2) is carried out.

4.

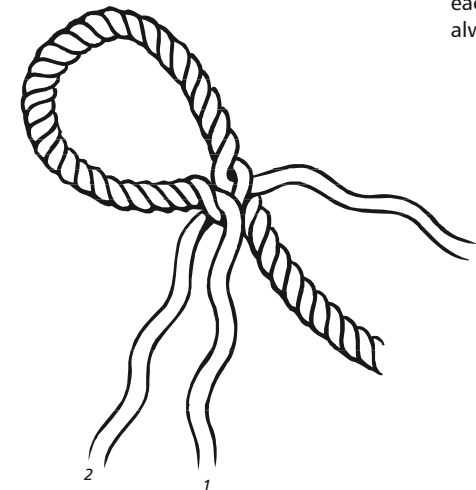

### Tucking through strand (3)

Now the other side of the eye is turned upwards and strand (3) is spliced under the remaining firm strand. We have thus placed each unravelled strand under a fixed strand, always against the lay of the rope.



5.

### The subsequent 3 complete tucks

From this point, the second tuck is carried out against the rope lay over the next fixed strand and under the following fixed strand. The same procedure is performed with strands (1) and (3). Each strand is spliced three times. By the removal of some rope yarns, tapering can be achieved and two further tucks can be done. The tapering gives the splice a slender stream-lined appearance.

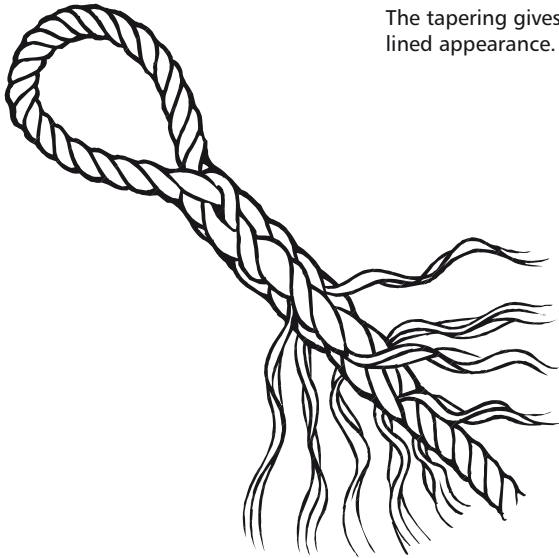

6.

### Completion of the splice

The overlapping strands and yarn ends are cut off – not too close to the rope – and can be heat sealed although a better method is to whip the splice end.

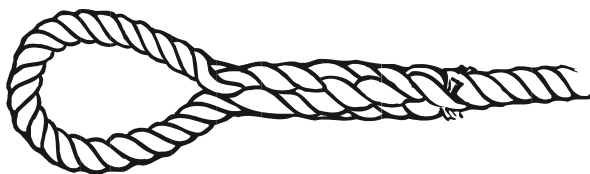

e.g. Polyamid, Geolon



### Construction and applications

Two pairs of strands twisted in clockwise and two pairs twisted in anti-clockwise directions, in such a way that they cross in the centre of the rope, form a square cross sectional shaped rope called Square Plait, 8 Strand Cross Plait, Square Line or other similarly descriptive name. Square Plaits have found their applications mainly in commercial marine (mooring) applications and fishing, as they cannot kink or deform and are torque-free. They work particularly well on capstan or hand-tailed type winches, have a relatively high constructional stretch and are easily spliced. These excellent properties make this type of construction very popular amongst yachtsmen and for mooring and anchoring applications.







# Eye Splice

Square plaited ropes are braided from 4-strand pairs. The strands are twisted either clockwise or anti-clockwise. This is also referred to as Z and S rope lay. The diagram illustrates how the direction of rope lay can be easily recognised. The splicing technique requires that Z strands are spliced only under Z-strands, and S-strands only under S-strands.

We have also tested this the other way around: Z-strands under S-strands and vice versa. The test results are the same. The first method corresponds more to "rope logic": In the case of a twisted rope, a strand twisted in one direction is also spliced under a strand likewise twisted in the same direction.

**Splicing tools:** Fid and tape

1.

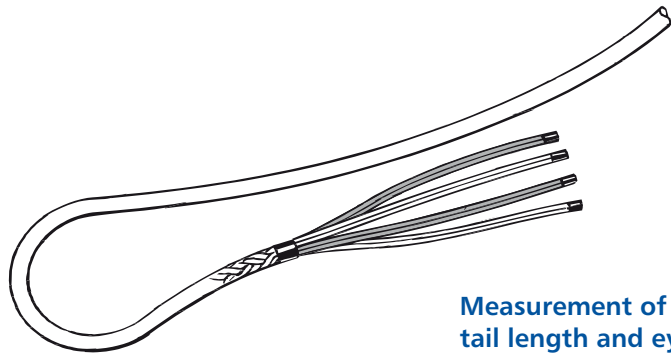
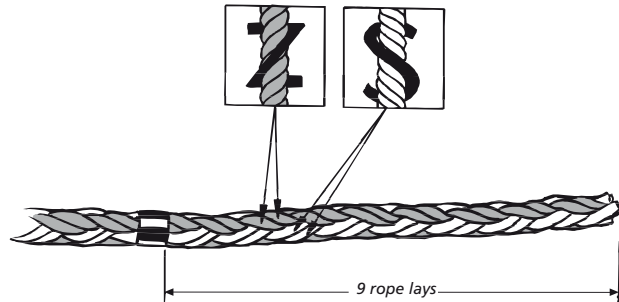

### Measurement of the tail length and eye size

The rope end is spliced back so this length is lost and therefore needs to be considered in the final length of the rope. Remove the tape from the rope end, or where applicable cut off the heat sealed section of the rope end. Tape each strand end with a layer of tape and thereafter use a thin layer of tape to stick the respective pairs of strands together. Unbraid the rope to a length of nine rope lays. Fix a layer of tape around the tenth lay, to prevent the rope from unravelling. Now determine the size of the eye.

2.

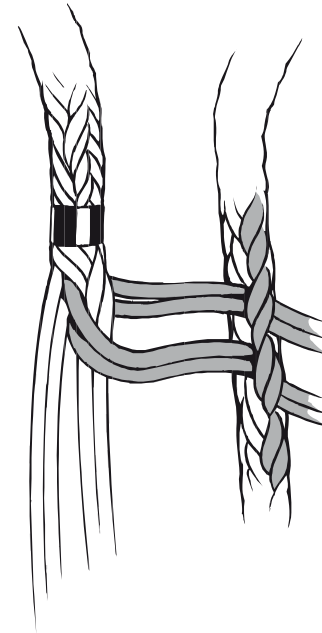

### The four initial tucks

We position the section that is to be spliced in such a manner, that two pairs of strands lie on top, and two at the bottom of the rope. The top strands are twisted in a Z- or respectively S-direction. Begin with the Z-pair of strands. As shown in the diagram, they are tucked under a Z-pair of strands. It is advantageous here, to use the fid to form the opening for this (as well as subsequent tucks) under the strands. Now, take the S-strand pair, and tuck them under the neighbouring pair of S-strands.

The splice is now rotated 180°. At this stage, proceed in the same manner as with the first two tucks. Pull all strands that you have passed through the rope evenly, but not too tight, so as to prevent the eye section swelling up.

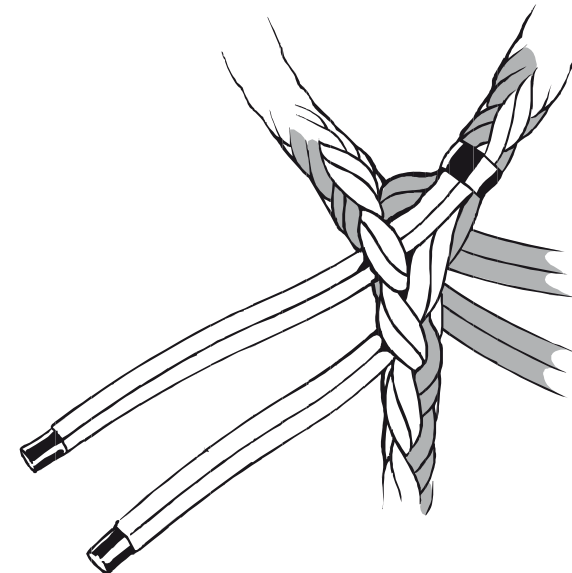

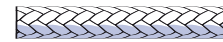

e.g. Polypropylene Hollow Braid



Eye-Splice



End-to-End-Splice

## 3.

### The next five double tucks

This step describes what happens to a pair of Z-strands that have already been tucked through the rope, in order to complete the splice. The remaining three pairs will be dealt with in the same manner later, hence we shall not repeat the description.

Remove the tape from the end of the pair of strands. The two strands are now lying against each other. Apart from the fixed pair of strands of the rope that were tucked under during the first step, there is another fixed pair of Z-strands. They are now individually tucked. One strand of the opened pair of strands is now tucked under a fixed strand, the other strand passes over the strand that has been spliced under and then passes under the second fixed strand.

The same procedure is repeated four times.

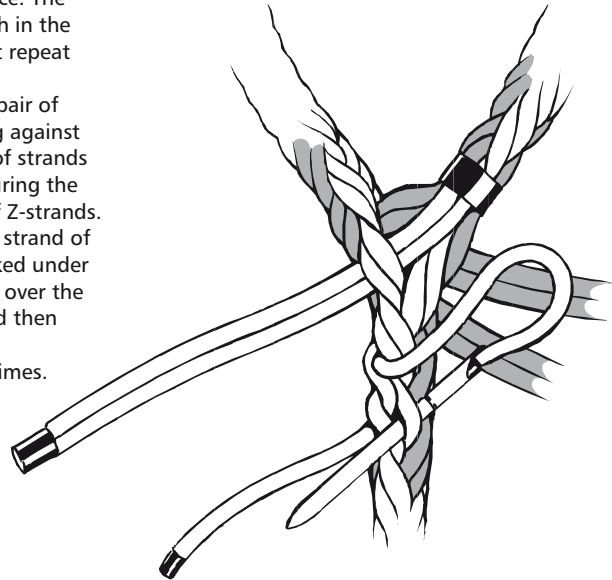

At this stage, the neighbouring pair of S-strands is treated in the same way just as the two remaining pairs of strands. After completion, the splice must look like that depicted in the diagram.

## 4.

### Completion of the splice

The strand ends still sticking out after the strands have been evenly tightened, are melted off smoothly, or the ends of the pairs bound by tape and then heat sealed.

The best looking method is to heat seal the strand ends until they are very short, and then to cover with a well sewn whipping.



### Construction and applications

A hollow braid is a round braid without a filler or core. It is essentially, a tube, woven or braided from an equal number of clockwise and anti-clockwise twisted strands.

The simple, effective construction of hollow braids makes them easy to splice using the characteristic of the hollow centre within the rope contracting when the rope is under tension. Anything (such as the tail of the rope itself) inserted into that hollow rope centre will be held securely by the contracting braid. Hollow braids are widely used for mooring and security lines. A hollow braid is a round braid without a filler or core. It is essentially, a tube, woven or braided from an equal number of clockwise and anti-clockwise twisted strands. The simple, effective construction of hollow braids makes them easy to splice using the characteristic of the hollow centre within the rope contracting when the rope is under tension. Anything (such as the tail of the rope itself) inserted into that hollow rope centre will be held securely by the contracting braid. Hollow braids are widely used for mooring and security lines.



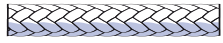

# Eye-Splice

Hollow braids for all intents and purposes, length of "hollow hose". Upon pressure load being exerted, these hoses become extended in length. Thus reducing the hollow space and holding fast the end of the rope that was introduced earlier. In order to prevent the rope end from being pulled out of the braided covering too easily upon easing of the load, four tucks are made, prior to the rope end disappearing.

1.

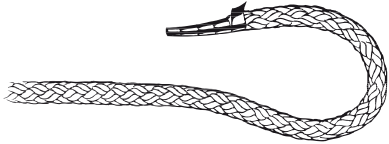

### Determining the length and eye size

Measure a length of 50 cm from the end of the braid and mark it. Then determine the eye from the point marked. It makes sense to make a second mark at this stage.

It is recommended to cut the rope end at a taper and to secure it with a layer of tape.

2.

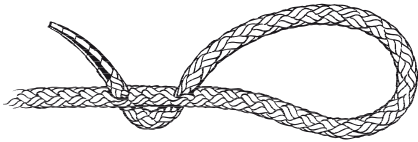

### First and second tucks

This splice can thus far be carried out without tools, the fid and pusher are nevertheless very useful. At the second mark, push a hole straight through the hollow braiding and pull the rope end through this hole until mark 1 reaches mark 2. At a distance of approx. 1–2 x rope diameter once more push a hole through the hollow braid and proceed in the same manner as before. The diagram shows the course of the braid.

3.



### Third and fourth tucks, completion of splice

Carry out tucking 3 and 4 in the same way as before. The splice is complete by way of letting the rope end disappear in the hollow braiding.

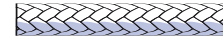

# End-to-End Splice

Hollow braid is like "empty hoses" that upon having load pressure exerted on it, draws together and contracts. If one wants to splice two ends together as a ring for instance, or for repairs, one lets the end of one rope disappear within the other and vice versa. For safety's sake, our splicing recommendations advise four tucks to be carried out beforehand, in order to prevent dislocation of the two that might otherwise occur when there is no load on the rope. The fid and pusher normally required for braid splicing are not imperative in this case, although still useful. Here, the splice can often be carried out without tools.

What is definitely needed are tape and scissors!

1.

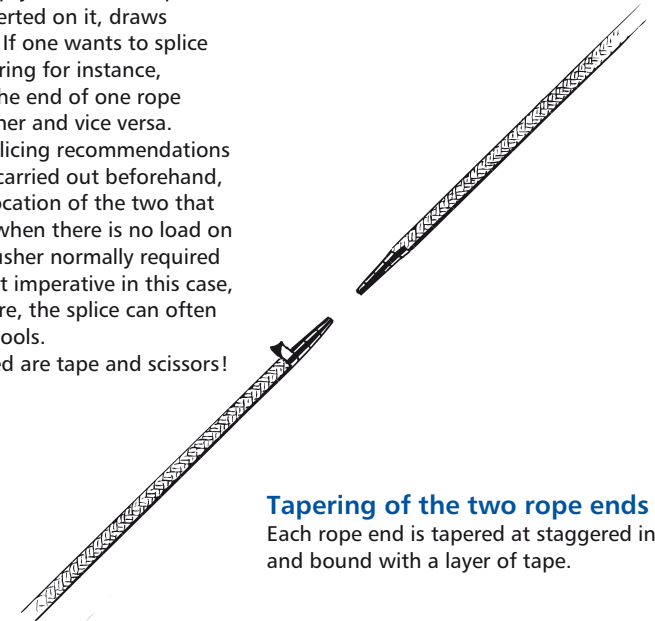

### Tapering of the two rope ends

Each rope end is tapered at staggered intervals and bound with a layer of tape.

2.

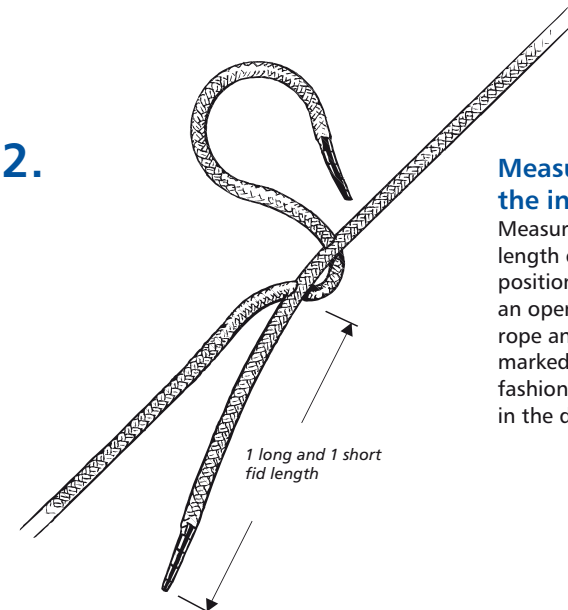

### Measuring the tail length, the initial tucks

Measure the distance of a long and short fid length on each rope and mark each rope at this position. Using either the fingers or the pusher, an opening is made at the marked spot on one rope and the rope pulled through up to the marked spot on it. One proceeds in a similar fashion, pushing the rope end back as depicted in the diagram.

1 long and 1 short fid length

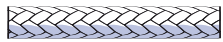

Hollow Braids



End-to-End Splice

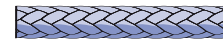

# Hollow Braids out of high modulus fibres

Splicebook 20|21

e.g. Dyna One, Dyneema Trimm



Eye-Splice

3.

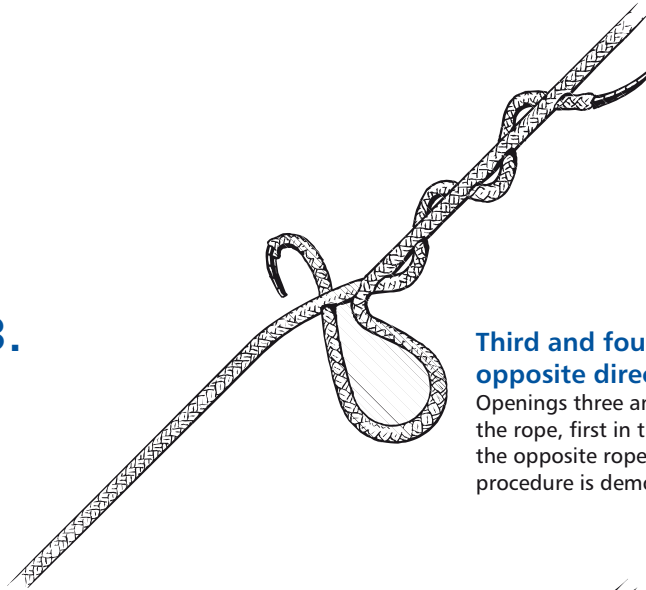

### Third and fourth tucks running in opposite directions

Openings three and four are tucked through the rope, first in the one rope, then in the opposite rope in the same manner. The procedure is demonstrated in the diagram.

4.

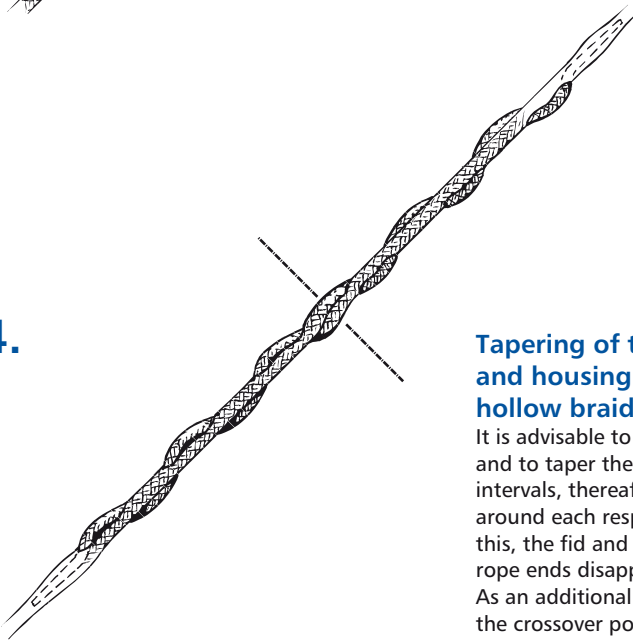

### Tapering of tail ends of the ropes and housing of these within the hollow braidwork

It is advisable to unlay both rope ends a little and to taper them somewhat at staggered intervals, thereafter binding a layer of tape around each respective end. Having completed this, the fid and pusher are used to make the rope ends disappear within the braiding cover. As an additional safeguard, we recommend that the crossover point of the braids, whipping twine is used to briefly sew both ropes together, to ensure that nothing is displaced in respect to each other.

### Construction and applications

The construction principle is the same as with standard hollow braids, the difference is the raw materials used and their very special characteristics. When splicing hollow braids of high modulus fibres, such as Dyneema, Vectran, Kevlar or Twaron, one must ensure that sufficient tail of rope is buried inside the hollow braid to give enough friction to hold these extremely high strength ropes.

If the splicing instructions are followed scrupulously, break loads superior to those of wire ropes of the same diameter (especially with DYNA ONE) can be achieved.

A correctly spliced DYNA ONE can be advantageously used in highly demanding applications such as backstays, backstay runners, spinnaker sheets and spinnaker runners.



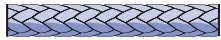

*Hollow Braids  
out of high  
modulus fibres*



*Eye-Splice*

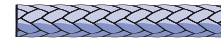

*Hollow Braids  
out of high  
modulus fibres*



*Eye-Splice*

# Eye-Splice

Dyna One is Gleistein's man-made fibre "steel wire rope". Its construction requires an accurate splicing technique. There will be no problems with our splicing instructions if they are strictly adhered to.

1.

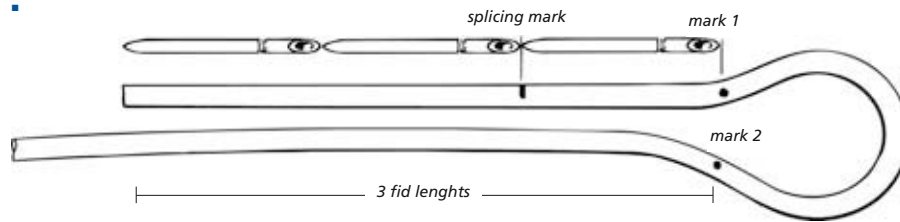

## Determining the eye size and marking the rope

Measure three fid lengths from the end of the rope and mark the braid with a dot. This is mark 1. Determine the size of the eye and mark the rope (mark 2) adjacent to mark 1. If a (reinforced) thimble is required ensure that the

rope is pulled tightly around it before making mark 2. For splicing mark (mark 3) measure one fid length from mark 1 towards the end of the rope.

2.

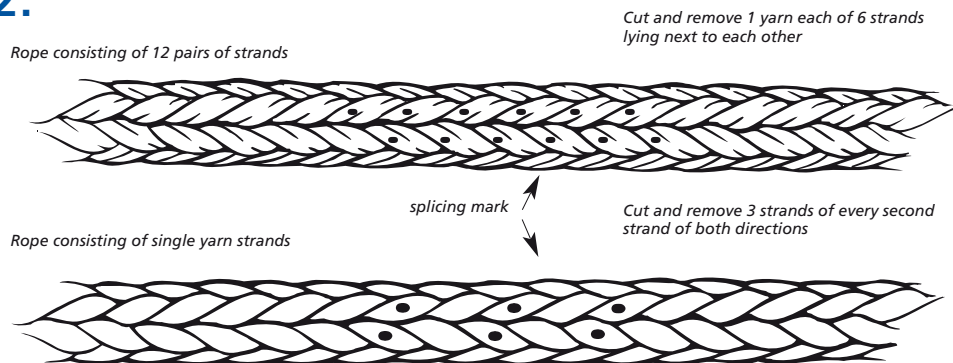

## Tapering the rope end

Start tapering at the splicing mark. Dyna One is a twelve-strand braid of which 6 strands run clockwise and six strands run in an anti-clockwise direction. The tapering procedure should

half the rope exactly. Look at the strands. If they consist of two parallel yarns, a length of 6 strands lying next to each other must be measured from the splicing mark.

3.

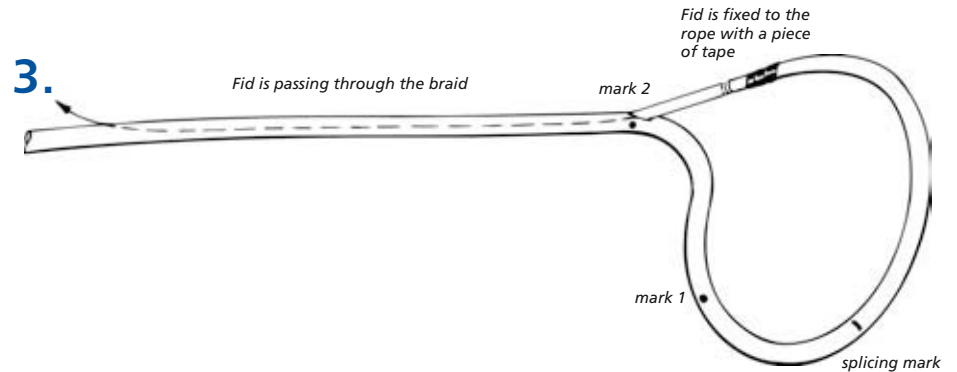

## Feeding the tail into the hollow rope

Insert the rope into the fid bore and fix the fid to the rope with a piece of tape. This fid is introduced into the rope at mark 2 and should

strand of one direction are cut and removed from the braid and the same with the opposite direction. Cutting ends at random now tapers the last 5-10 centimetres of the tail of the rope.

emerge after about three fid lengths. Bunch up the braid until the splicing mark reappears. mark 1 and mark 2 should be close together.

4.

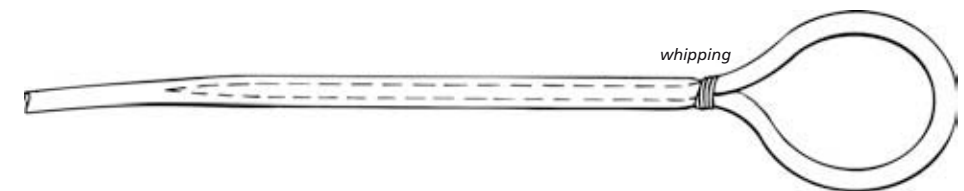

## Completion of the splice

Start from mark 2 to milk the slack out of the rope. The rope end disappears in the hollow braid. It is essential to secure the eye splice with lock stitching and a well-sewn whipping to prevent the splice from being pulled out before its initial use. Ensure that the splicing area is completely smooth.

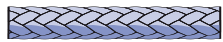

Hollow Braids  
out of high  
modulus fibres



End-to-End-Splice

## End-to-End Splice

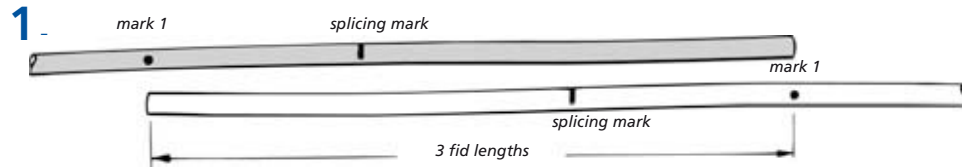

### Measurement of splicing allowance and splicing marks

Make mark 1 three fid lengths from both of the ends to be spliced, measure one fid length from mark 1 towards the end of each rope.

2.

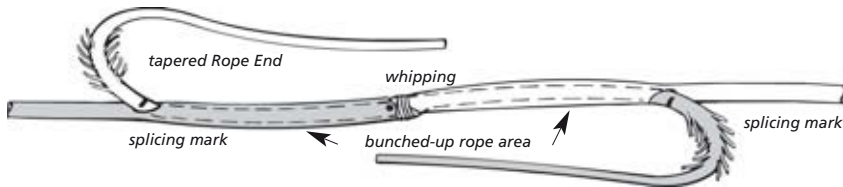

### Place both ropes in splicing position

Fix one rope end with a piece of tape to the fid bore and insert it into the other rope end at mark 1, feed the fid through this rope until

both mark 1's are adjacent to each other. Secure this area with lock stitching and a secure whipping and repeat with the other rope end.

3.

### Tapering the rope ends

Refer to point 3 of page 23. Taper both rope ends in the same way.

4.

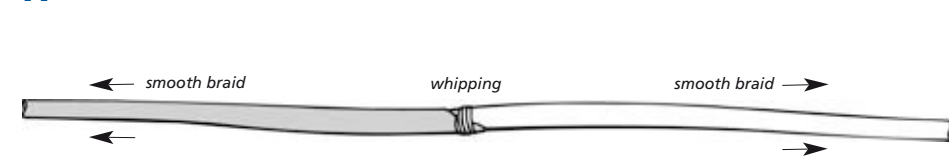

### Completion of the splice

Smooth both ends from the whipping along the rope.



## Double Braids

e.g. Gemini X, Tasmania, Harkon Standard, Bavaria, Dockline



Eye-Splice



End-to-End-Splice



Back-Splice



### Construction and Applications

This construction is produced by braiding a round cover over a round core and gives a compact rope with a high break load evenly distributed between core and cover.

Double Braids have numerous applications on board such as halyards, sheets, lazy jacks and mooring ropes and provide a versatility unequalled by any other modern construction.



# Eye-Splice

## 1.

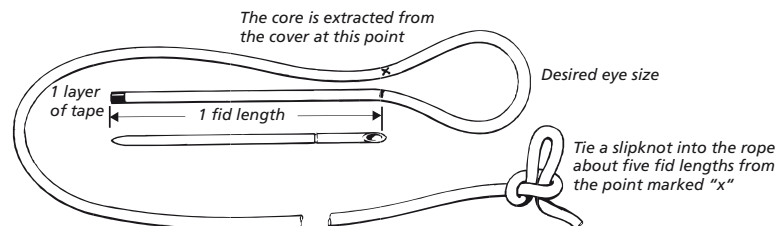

### Measuring of the eye

The rope end must be taped – not heat sealed. mark a thick dot on the rope, one fid length from the end of the rope. Use this marked point as the starting position for forming the eye to the required size and mark the rope at that point with an “x” as shown in the sketch. In step 2, the core is extracted from the cover at

this position. Now tie a slipknot into the rope about five fid lengths away from the “x” mark. This knot prevents the dislocation of the remaining rope from the cover during the splicing procedure. Where a thimble needs to be spliced into the eye, it is necessary to measure the eye size around the thimble.

## 2.

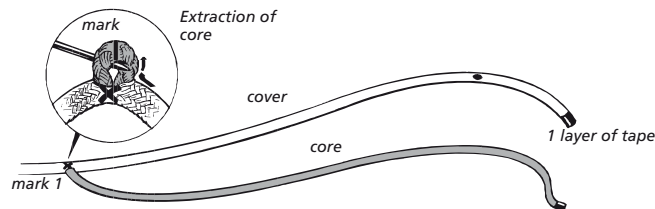

### Removal of core from cover

Make a sharp bend in the rope at point “x”. Carefully push the cover yarns to the side so that a hole is created in the braiding. The tip of the pusher is useful for enlarging the hole at this stage. Push the tip of the pusher under the core.

Before extracting the core from the cover fully, draw position mark 1 on the core. Remove the core from the cover completely, so that the end of the core is fully outside. Bind the end of the core tightly with a soft tape.

## 3.

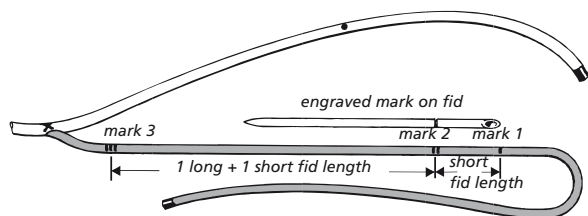

### Marking the core

As evident from the diagram, extract more of the core from the cover. From mark 1, measure a short fid length and mark that position on the core as mark 2. Then from mark 2, measure the distance of one whole and one short fid length

and mark that point as mark 3. Compare these measurements with the drawing once more. It is advisable at the start, to indicate mark 1 by one ring around the core, mark 2 by two rings and mark 3 by three rings.

## 4.

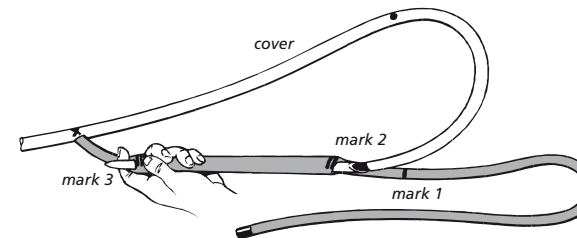

### Pushing of fid through the core

The fid is introduced into the core at mark 2, further through the cover, and reappears at mark 3. A tunnel is formed in this way, which is

utilised in step 5 to house the end of the cover in the core braiding.

## 5.

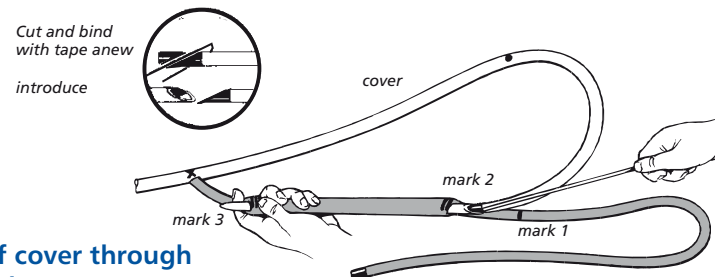

### Pushing of cover through core tunnel

Cut the cover end to a taper with scissors or a knife – and bind this pointed tip fast with a layer of tape. The tapered point is positioned within the fid bore and pushed into it firmly with the assistance of the pusher. The core is

held lightly at mark 3, in order to push the cover from mark 2 to mark 3 through the core with the aid of the pusher. The end of the cover is pulled out of the core a little.



6.

Fid and core are introduced into the diameter further than "x" from the cover

Reintroduce the fid and core end at the same point at which they emerged

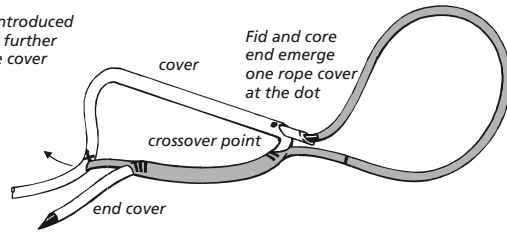

### Pushing of fid and core end through cover

First look at the diagram carefully. It will be discerned that the core end must be passed through the cover, namely between the dot and the opening "x", more precisely, approximately one rope diameter further behind "x". The fid is inserted in the cover at the marked dot. This is the crossover point. The fid is pushed through the cover to a distance of one rope diameter further than "x". The taped core end is pressed into the fid bore, and the core end pushed through the cover with the fid and the pusher.

The core end is pulled until the core has fully passed through the cover. By pulling the end of the cover, the crossover point is pulled shut. It should be noted that with small eyes, the steps outlined above suffice. If the eye is required to be larger however, the fid will not be long enough to reach from the dot to "x" in one procedure. In this case it is done stepwise by coming out of the braided cover and carrying on the task from that position.

7.

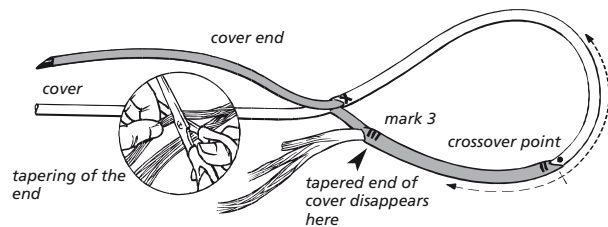

### Tapering of the end of the cover

The end of the cover remains in the core upon completion of the splice. A tapering of the end of the cover makes the splice look good and increases its strength. To facilitate tapering, the tape must first be removed from the end of the cover. Thereafter, the cover braid is unravelled as far as possible and then cut out stepped

fashion. Now the rope is held at the crossover point and the loose of the core "milked" away. This causes the end of the cover to disappear into the core. Hereafter, the loose is "milked" or brushed out of the cover (refer to diagram), until the braid cover is once more taut.



8.

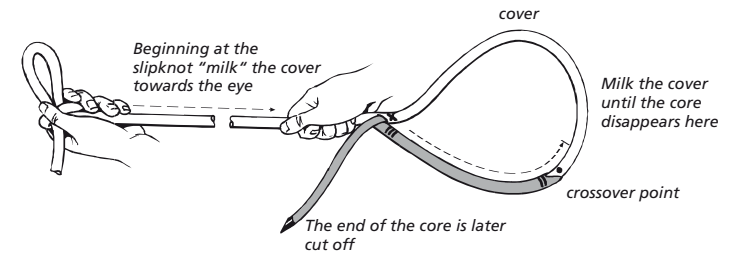

### The cover is "milked" down over the core

Either hold the rope by the slipknot made earlier, or even better, place the slipknot over a hook. Now hold the rope taut by the core braiding and "milk" the loose cover, keeping the core under constant tension, whilst the loose

only one that may present some difficulties to the layperson. Do not attempt to complete this procedure in one go, but rather in several operations. Ultimately, the core is swallowed by the cover at the crossover point. The core end still protruding is cut off. Then it is necessary to pull on the eye-splice to smooth the rope.

9.

### Completion of the splice

When the "swallowing" in step 8 does not happen easily: If not enough care is taken, the core bunches up at the crossover point. This can hinder the "swallowing up" process. Where this occurs, the "milked" cover must be brushed back in the direction of the slipknot and the

earlier step repeated, until the core has completely disappeared. The whole procedure can sometimes be made easier by moving the rope to and fro in the area around the crossover point.

10.

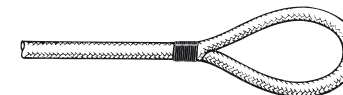

### Final step

The splice should look like the one shown in the diagram. We recommend a simple whipping of the eye at the crossover point. Should a hollow spot appear at the throat because the core tail was cut off too close, this is merely aesthetically irritating, but does not reduce the strength.

The reason for this is that in the eye of the rope, the tension load is distributed over both sides. Each side therefore has to withstand 50% of the total load, a feat that the cover alone is capable of handling.





# End-to-End-Splice

The splicing tools for the End-to-End splice are the same as those used for all braided ropes. There are two variations to the End-to-End splice: With the plain method, there is a slight thickening at the rope end, whereas with the

precise method the thickened end disappears. The decisive difference lies in the tapering of the respective core and cover ends. It is of great advantage with End-to-End splicing to have mastered the eye splice with this double braid.

1.

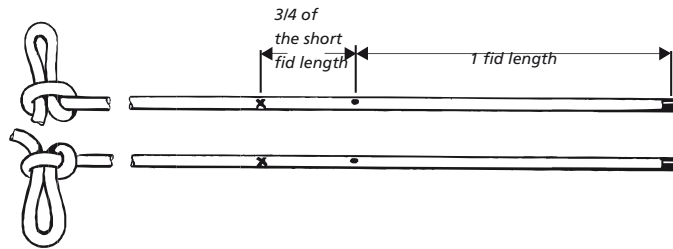

### Marking the cover

Tape both rope ends with adhesive tape, do not heat seal them. If the ends have been heat sealed, these parts have to be cut off. Position both ropes in the manner portrayed in the diagram, as exactly the same measurements must be marked on each rope. Measure one fid length from the end of the rope and mark with a dot. From this dot, measure three-quarters

of a short fid length and mark the spot with an "x". From "x" (on both ropes) measure five fid lengths and tie a slipknot. The reason for this is that during splicing, the core is pushed and dislocated from the cover. The knots prevent a further shifting of the displacement down the rope.

2.

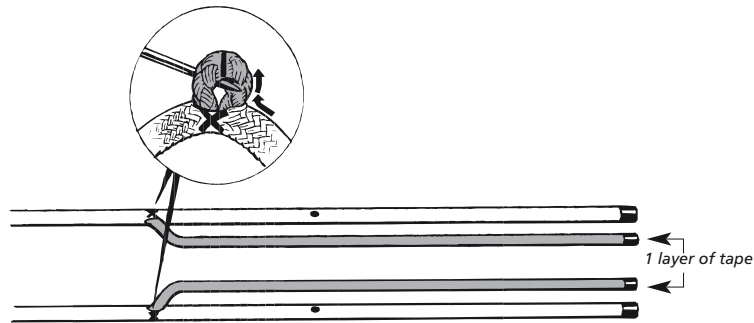

### Extraction of the core from the cover

Make a sharp bend at the ropes at "x" and push the yarns of the cover away from "x", to make an opening. The braided core now appears. Before pulling it out of the respective braided cover it is marked by a 1 or even better, by a

ring around the core. The respective core is then pulled out of the cover using the pusher and the end of the rope is taped firmly with a layer of tape.

3.

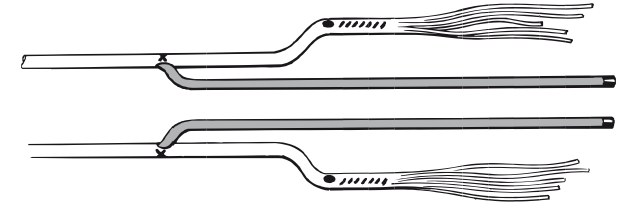

### Tapering of core tail and end of the cover

#### a) Plain method

The core end is tapered by way of the already taped rope end being cut off diagonally. The end of the core on the other hand is tapered from a point seven yarn pairs away from the dot marked earlier. This crossover point is marked with a "k". Remove the tape from the

end of the braided cover and unravel the rope cover up to point "k". The bundle of fibres resulting from this must be cut in a stepped manner in order to taper it. The new rope end is taped.

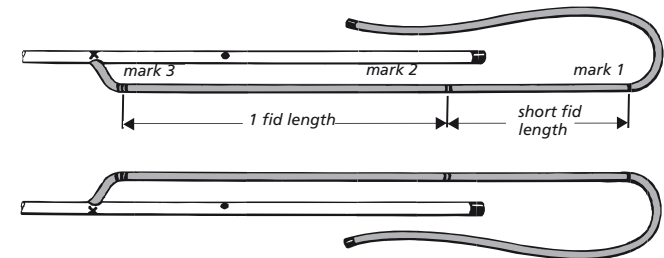

#### b) Precise method

In the precise method, both the core and cover ends are halved exactly. Pull more length of the core from the cover and place a layer of tape around the core ends. Measure one short fid length from the position marked 1 to the slip

knot on the core, marking the spot as 2 (or even better draw 2 rings around the core). Next, measure one complete fid length from point 2 in the direction of the slipknot and mark it as 3 (3 rings around the core).



Now look at the core braid more closely. It consists of braided yarn groupings. Some run clockwise and some anti-clockwise. As in the diagram, first mark 2 groups of yarns lying parallel, but running in opposite directions, then jump two and repeat the marking until there is a total of 4 x 2 groups marked. Each group consists of an even or uneven number of yarns. Halve the marked groups, sever half of them and pull the fibres that have been cut out of the rope end. The tape at the end of the rope maintains the shape of the "left over" rope. Halving is simple in the case of even strands of yarn. With an uneven number

this can only be done in the following manner: Remove one yarn from one group, two from the next, then one again, and so on. The end of the cover is tapered correspondingly. From the dot, count 7 pairs of yarns in the direction of the cover end, and mark the crossover point "k" there. From "k", all pairs of yarns of the cover are halved by cutting one yarn out of each pair and pulling it out. This is best done in the following manner: From "k" in the direction of the rope end, mark six pairs of yarns of each lay direction, so that one is always skipped over. Of these pairs, one is always cut out and removed.



4.

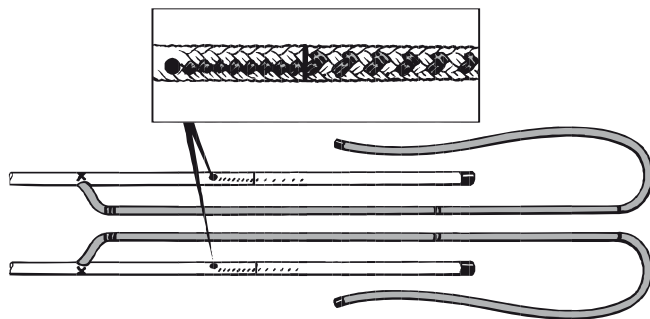

### Placing of ropes in splicing position

When both rope ends have been tapered in the same way (more precisely: the 2 core ends and the 2 cover ends), the ropes are placed in splicing position as demonstrated in the diagram. If a continuous rope loop is to be spliced in, it is important to check that the ropes have not be

come twisted. This does not matter when two rope ends are spliced together. Should it be necessary to splice a ring into a rope loop for instance, it must be slipped over one of the ropes at this stage.

5.

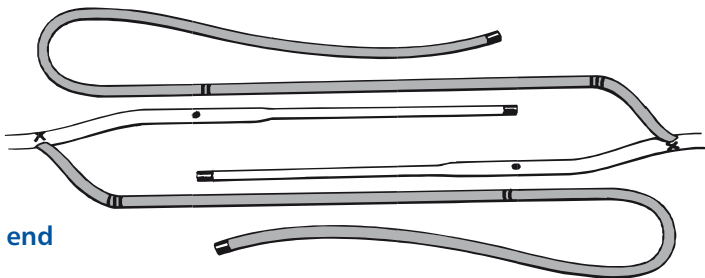

### Pushing the cover end through the core

The fid is introduced into a core at the position marked 2 and exits it again at position 3. The end of the cover of the second rope is placed into the fid bore and held there by the pusher passing through the core until it emerges at point 3 after having entered at point 2.

The cover end of the second rope is treated correspondingly. Both cover ends are respectively positioned correctly when the crossover point "k" appears at the marked position 2.

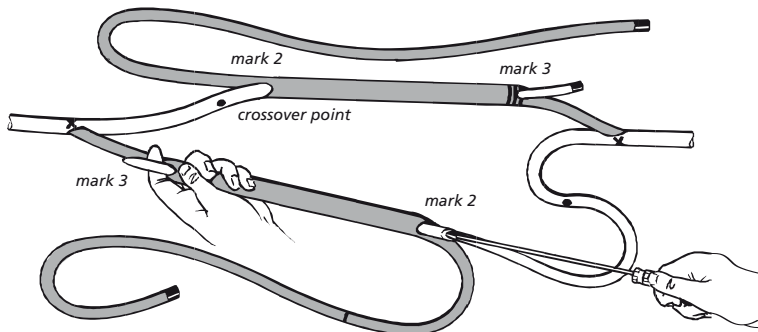

6.

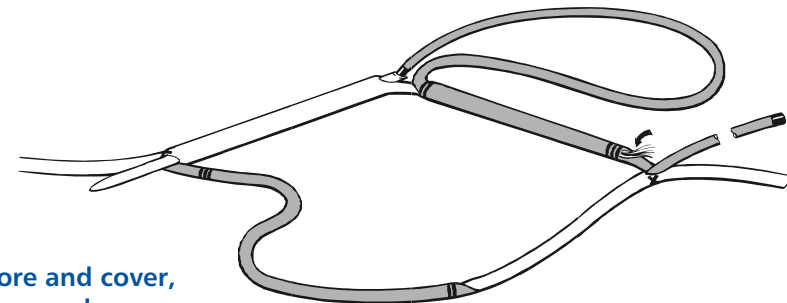

### Guiding of core and cover, pulling in cover ends

Insert fid approx. one rope diameter next to "k", into the cover and push 3-4 cm through the cover on the other side of "x". Place the core end into the fid bore and push the core end through the cover with the pusher. The respective ropes then cross each other at point "k" and position 2. Pull carefully on both respective rope ends so that the point of intersection can settle. Avoid pulling in any

lumps. Now the first intersection position is held by one hand from where the core is successively stroked smooth and even. The cover end now disappears completely within the core. Now the cover is stroked smooth, starting from the crossover point so that the core will attain the correct position. Needless to say, the same procedure must be carried with each "part rope".

7.

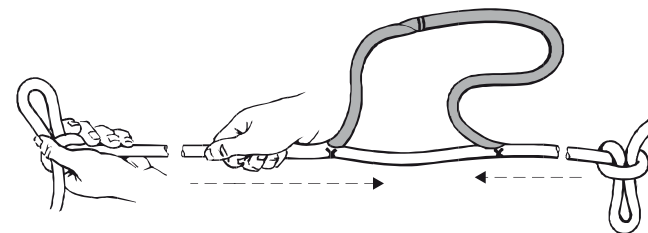

### Drawing together and completion of the splice

We now place a slipknot over a fixed hook and pull the core of the rope that we have attached to the hook, taut in the region of the splice, towards the hook. With the other hand, we milk the cover over the core. First the position mark 3 will disappear, then the crossover point at 2. After this, the slipknot of the other rope is fixed to the hook and the same procedure carried out as with the other rope. This results in the hole between the two "part ropes" becoming increasingly smaller until it ultimately slips together completely. If all the taperings in the previous steps were carried out correctly, then the left

and right cover openings will be pushed against each other and the splice will not have any swelling. With the plain method on the other hand, a swelling will remain, since only the end of the cover was tapered not the core, the core is thus doubled up in this type of splice. Cut the core ends till sticking out close to their exit points. Hereafter, sewing (whipping) of the completed splice is recommended. If all the measurements were made precisely and the work was carried out according to the instructions, the splice will succeed at the first go.



# Back-Splice

The back splice in double braid is a clean and safe way of finishing a rope end. Whipping is not required, one has a flexible rope to the end and can halve all the measurements given by the instructions if the back splice appears to be too long.

**Splicing tools:** You will require the tools that are used for the other braided rope splices in this book.

1.

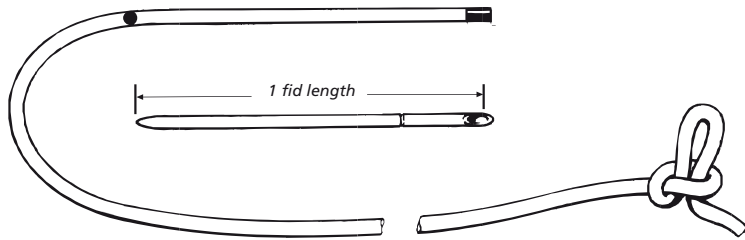

### Measurement of the rope end

The rope end is taped with a layer of adhesive tape. Should the rope end have been heat sealed, that section has to be cut off. Measure one fid length from the rope cover end and mark it on the cover with a dot.

Make a slipknot in the rope about six fid lengths from the dot. Reason: During splicing the core is displaced in relation to the cover. This slipknot prevents further running of the dislocation.

2.

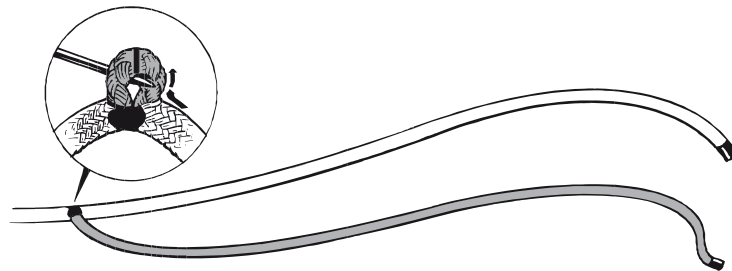

### Extraction of core from cover

Bend the rope sharply at the dot. Spread the cover strands to the side with the fingers so that an opening results in the cover braid. Pry the core out of the cover with the pusher or

another pointed tool. Then mark the core with a 1 where it emerges from the cover, pull the core end out and stick a layer of adhesive tape around the core end.

3.

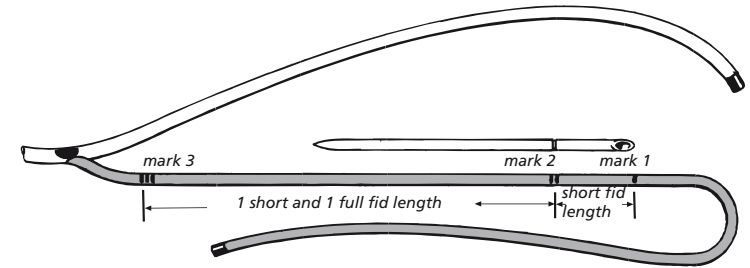

### Marking of the core

Extract more of the core from the cover, then measure a short fid length from mark 1 on the core and mark the spot as mark 2.

Thereafter, mark the core mark 3, one short and one whole fid length distance onto the core.

4.

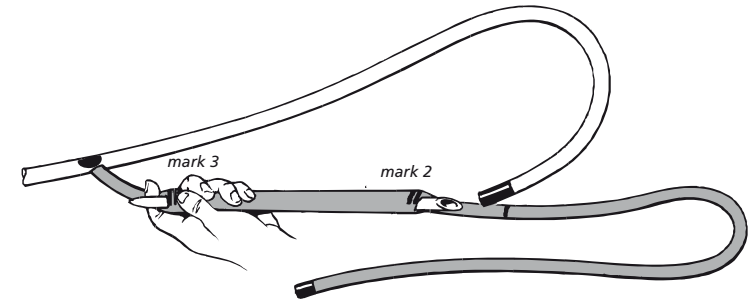

### Pushing the cover end into the core

Cut off the tapered end of the cover at an angle marking a point that is held by the tape. The fid is inserted into the core braid at mark 2 and emerges at mark 3. Place the cover end into the

fid bore, jam the cover end into the bore with the pusher and push the fid and the cover through the core.



Double Braids



Back-Splice



# Braids with parallel fibre cores

Cup, Cup Classic



Eye-Splice

5.

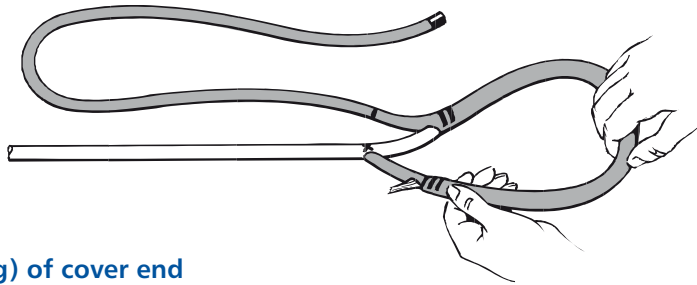

## Positioning (burying) of cover end in core

Remove the tape from the end of the cover. Unravel the cover end somewhat and cut some fibres off stepwise so that the end of the cover is tapered. Milk the slack of the core from mark 2 into the direction of mark 3. When the end of

the cover has just disappeared within the core, hold the core fast at mark 3 and now milk the slack in the direction of mark 2, until all the slack has disappeared.

6.

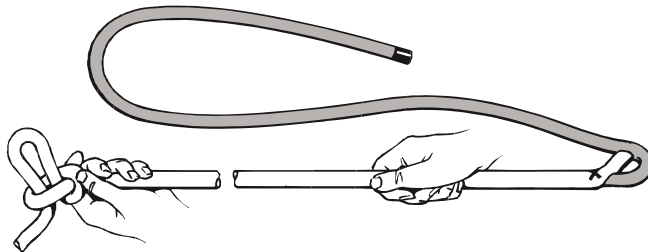

## The slack is milked out of the cover

Attach the rope to a hook by the slipknot. Milk the slack out of the cover towards the rope end, initially very carefully, thereafter progressively more intensively. The core will engulf mark 3 first, then mark 2 and ultimately even the dot.

The procedure is a little difficult, so do not attempt to do it in one go, but rather instages. occasional kneading of the end of the rope helps in splicing.

7.



## Finishing off of the splice

Cut the end of the core close to the point of emergence at the splice location and milk the remaining slack from the cover. The core end

will

disappear inside the rope and the splice has been completed.



## Construction and Applications

A construction composed of tightly packed parallel fibres surrounded by a protective cover braid. An intermediate braided cover is usually included to improve the ropes stability and give a better friction adhesion between outer cover and core. This unique construction provides optimal realisation of the fibre's tensile strength with minimal stretch behaviour. The parallel fibre core gives zero constructional stretch. This construction requires a special splicing technique, as the core of the rope will not contract under tension. Properly spliced, this construction provides an excellent solution to applications requiring the highest strength, lowest elongation and greatest durability for a given raw material



Braids with parallel fibre cores



Eye-Splice



Braids with parallel fibre cores



Eye-Splice

# Eye Splice

Preliminary information: Braids are always "hoses". Under tensile stress they become extended lengthwise, thereby becoming narrower. This "draw-stocking-effect" is utilised, by allowing the braid ends to withdraw back into themselves, thus holding the eyes together. This principle is not facilitated by CUP, as the core is compact, filled with fibres, which does

not allow the core to be spliced back. Hence the end of the cover is taped to the core by a layer of adhesive tape. The cover lying above, produces the necessary pressure against the core to effect a friction hold. The splicing tools are the same as utilised with other ropes.

1.

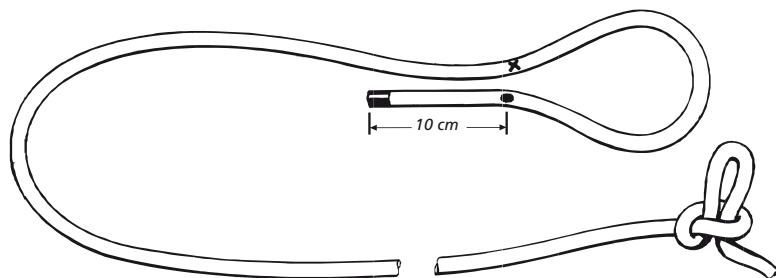

## Measurement of the eye

A layer of tape seals the end of the rope. It must not be heat sealed! Cut off possible heat sealed sections. mark a conspicuous dot about 10 cm from the end of the rope. Starting from the dot, form the eye to the desired size. Thus we locate the point "x", opposite the dot mark (after having formed the eye). At the point "x", the core is pried out of the cover during step 2.

Tie a slipknot into the rope at a distance of about five fid lengths from "x". This knot prevents the shifting of the core in respect to the cover in the remainder of the rope during splicing. Where a thimble is to be spliced into the rope, the eye-size is measured over the thimble.

2.

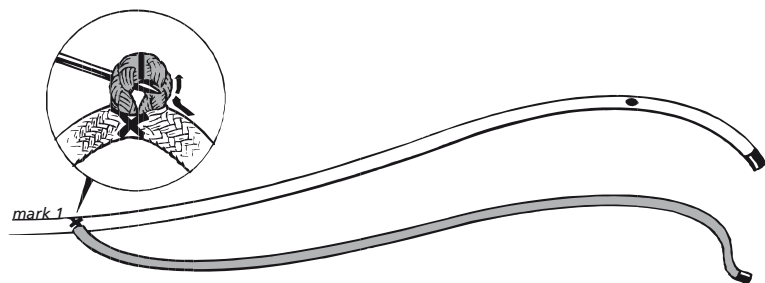

## Extraction of core from the cover

Make a sharp bend in the rope at "x" and bend it to and fro at this spot to make it more flexible. Push the covering yarns to the side with the pusher until a hole has been made in the braiding.

The core is pulled out of the cover at this spot and marked as 1. Cut off the core end at an angle and shape the point at the end with a layer of tape. **Do not heat seal!!!**

3.

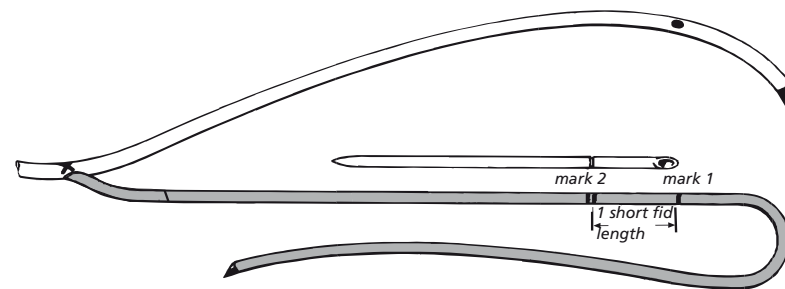

## Marking of the core

More of the core is pulled from the cover. The core-cover displacement which occurs here

ends at the slipknot. From mark 1, measure a short fid length and the spot 2.

4.

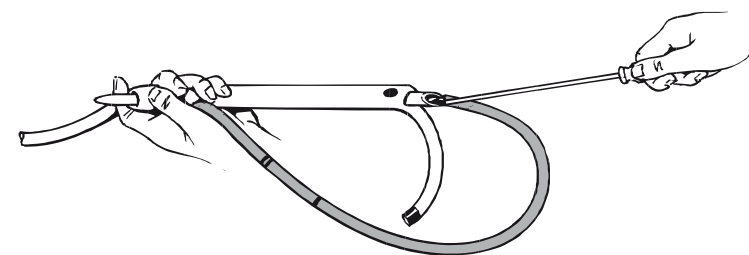

## Pushing of fid and core through the cover

The fid is inserted in the cover braid at the dot and re-emerges 2-3 cm the other side of "x". The core end is placed in the fid bore and pushed through the cover with the assistance of the pusher. At the point of re-emergence the

core is taken out again and pulled through the cover zone until mark 2 of the core disappears under the cover. The core is then fixed in that position with a taut layer of tape. The tape is wound tightly around the cover at the dot.



Braids with parallel fibre cores



Eye-Splice

5.

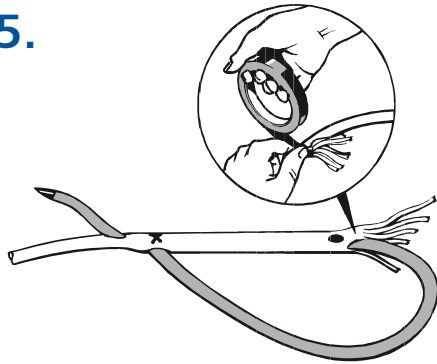

### Tapering and fixing of the cover end

The tape is removed from the end of the cover. The trail of the cover is unravelled up to the tape near the dot. The bundle of yarns that is established by this means is cut stepped with scissors, tapered and thereafter wound around the core – starting at the dot, it is tied fast to the core. Care must be taken that the tape is smooth and wrapped around the rope without obtrusive kinks.

6.

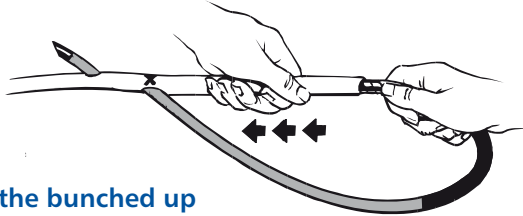

### Milking of the bunched up cover out of the eye

In the vicinity of the eye i.e. between the dot and "x", the cover has bunched up during splicing. The splicing section is now held near the dot, and the bunched up cover milked away in the direction of "x". During this procedure more and more of the core end disappears

within the cover. After all the loose of the cover has been milked away, the end of the core is cut off closely at the point of emergence. The remaining core disappears completely upon the final milking away of residual bunches.

7.

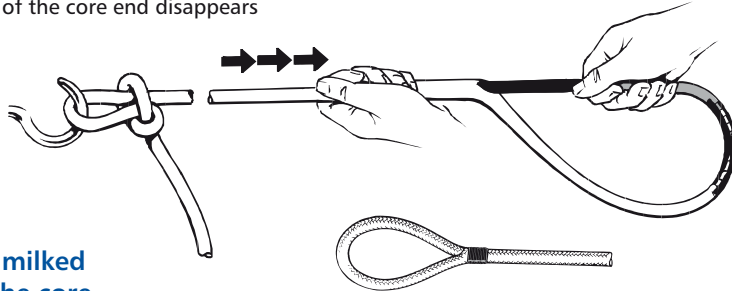

### The cover is milked down over the core

The final step is the only one that might be problematical to the layperson. The cover is milked back over the core loop. However the loop ends up swollen because of the layer of tape holding the yarn ends, which causes the shape of the cover braid to be impaired, resulting in resistance. Here it is advisable to follow the directions carefully: Place the slip-knot over a hook as shown in the diagram. Pull the core taut. With the other hand, milk the

loose bunched up cover over the core. Ultimately, the cover swallows the entire core section. Should this step prove difficult, then it is useful to brush the possibly bunched up cover back again and repeat the step a further time. Another possibility is to beat the splice area soft and flexible with the fid or a wooden mallet as by this means the yarns of the cover braid will more readily rearrange themselves into the new position.



## Braids with parallel twine cores

Splicebook 40|41

e.g. Riviera



Eye Splice



### Construction and Applications

These ropes consist of a core of an equal number of clockwise and anticlockwise twisted twines held together by a protective and compact braided cover. Although less expensive to manufacture than double braids they do an excellent job as sheets and halyards on smaller cruising vessels and provide a cost effective, economic alternative for the OEM (Original Equipment Manufacturer).



Braids with parallel  
twine cores



Eye-Splice



Braids with parallel  
twine cores



Eye-Splice

## Eye Splice

These instructions are applicable to all the other types of braiding in which the core does not consist of braiding, or where there is a CUP construction. The splice is load bearing, as the core tail which has been led back is held by the cover.

The most suitable splicing tools are a conventional Swedish fid and a splicing needle which can be made from a thick bent piece of wire with a slot drilled in one end. The wire should be 40–50 cm long and have the other end doubled up as a handle.

1.

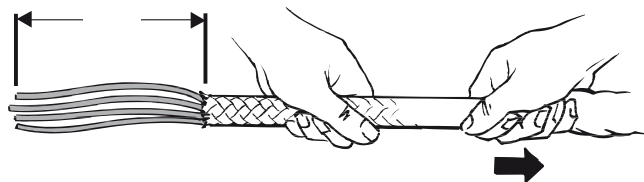

### Preparation of the splice

Tie a slipknot in the rope at a distance about 3 cm from the end. The core tail that is led back makes the cover swell up. The cover will only follow if it has adequate looseness. If the rope

end has been hed sealed, it is cut off, and in the case of taping, it is removed. Now push the cover about 15 cm over the core, and milk the slack created into the direction of the slipknot.

2.

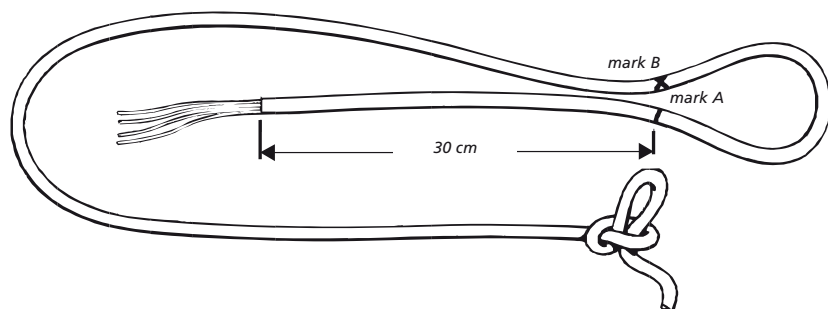

### Measuring of the eye

Measure 30 cm from the end of the cover and mark the cover with an "A" at this spot.

Determine the eye at the desired size and place the mark "B" on the cover.

3.

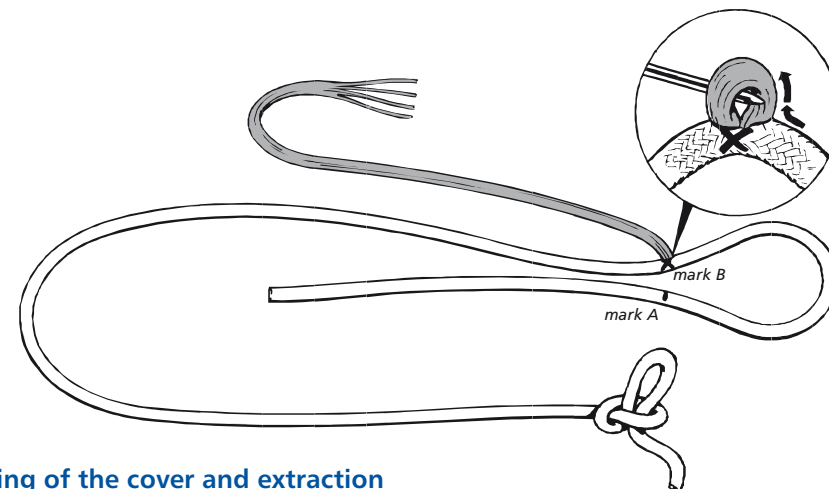

### Opening of the cover and extraction of the core from the cover

The cover is opened at the spot marked "B". If the splicing instructions are adhered to, this should prove to be relatively easy. All other methods may prove more difficult. Take the fid and push its tip under a strand (this strand can for all intents and purposes consist of several parallel yarns), and loosen the yarns. Turning the marline spike around in the process turns

sufficient looseness into the strand. Repeat this procedure with a number of strands around the location of "B" and pry out the rope core with the aid of the marline spike. Place the core parallel to the end of the cover and put a layer of tape around the core at "A" as well as one layer around the cores end.

4.

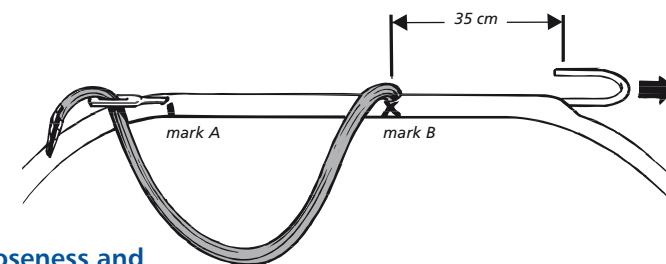

### Milking back the looseness and wrinkled braids of the cover, and insertion of the wire fid

Milk all the slackness that was created in the cover during step 1 in the direction of the slipknot in the direction of position "B". The core must not shift its position regard to the cover in the process. About 35 cm from "B", in the direction of the slipknot, the splicing needle re-emerges from the cover at "A". Care must be taken not to snag the core during this activity,

as this would bunch the core up. Halve the core by cutting out and removing yarn fibres, then place the core tail into the fid bore and pull the core end from "A" to the point of emergence of the fid. The points "A" and "B" now lie next to each other. Taper the core end a little more in stepped fashion.



Braids with parallel twine cores



Eye-Splice

5.

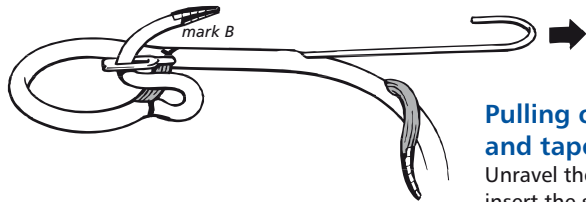

### Pulling of cover tail into the cover and tapering

Unravel the end of the cover up to "A". Then insert the splicing needle into the cover about 20 cm from "B". The needle re-emerges at "B". Now place the tail of the cover in the slot and pull the cover into the cover braid.

6.

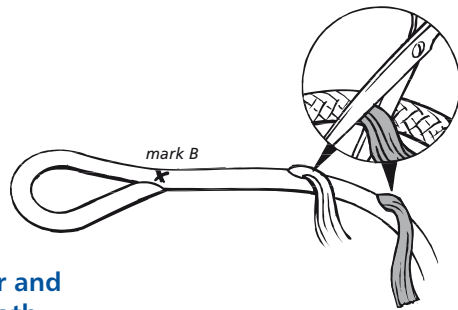

### Tapering the end of the cover and brushing the splice area smooth

The end of the cover is now tapered progressively along its complete length. Then the slack is stroked out of the cover, beginning at "B", in the direction of the slipknot, after that, the protruding strand ends and or cover ends are

cropped close to the point of emergence. Once more, stroke the splice area smooth, until the yarn ends disappear into the braid.

7.

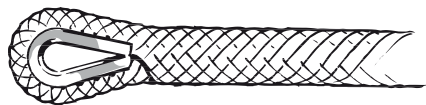

### Splicing in a thimble

If a thimble needs to be spliced in, this is inserted in the eye shortly before the last milking of the slack. After this, the remaining slack of the cover is stroked into the direction of the eye.



## Ropes with high modulus fibre cores

e.g. Vectran, Dyneema, Dyneema Classic, Dynamix, Dyna Lite, Caribic Color



Eye-Splice  
Method 1, Core-to-Core Splice  
Method 2, Core-to-Core Splice



### Construction and Applications

These ropes are highly specialised constructions for the most demanding applications. Braided cores of high modulus fibres, such as Dyneema, Vectran or Kevlar feature technical characteristics, in terms of break load and stretch behaviour, that can be an improvement on those of a steel wire rope. The load-bearing core has a braided protective cover of high tenacity polyester. An additional intermediate cover over the core improves friction between the load bearing centre and the protective cover for more efficient use in stoppers.

This section of our splice book introduces advanced splicing techniques, which require close adherence to the instructions and care in their application. In this way splices can be produced that will transfer the physical properties of these high quality lines into practical use on board resulting in the ultimate performance, durability and safety for halyards, sheets, guys and other applications.





Ropes with high modulus fibre cores



Eye-Splice, Method 1



Ropes with high modulus fibre cores



Eye-Splice, Method 1

# Eye Splice, Method 1

With all ropes made of high modulus chemical fibres, the load is carried almost exclusively by the core. The cover provides protection against light and abrasion. Consequently during splicing, the core must be spliced back into the core and the cover bound into the eye. There are basically two splicing possibilities.

These differ essentially in the whereabouts of the end of the cover. Both methods are described here. Both methods presume basic knowledge and require care. The second one is the more elegant of the two but requires more time. The splicing tools are the same as those used for all braided ropes.

## 1.

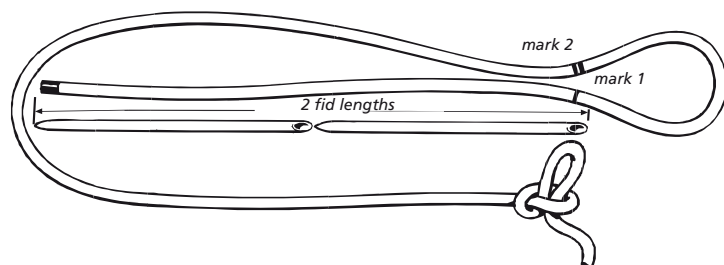

### Preparation of the rope end and measuring of the eye

The rope end must be taped not heat sealed. Should it have been heat sealed, then that section must be cut off.

In the case of our rope types Vectran and Dyneema there is a white staple fibre cover braided around the core proper. This intermediate cover must be removed from the entire area of the splice. Milk the cover over the core to such a length that about six fid lengths of the core can be seen. The intermediate cover is then cut off at that point and removed from the core. The remaining end of the intermediate cover is fixed to the core by means of a layer of tape. The cover is then milked back to cover

the end of the rope. This step is not necessary with Dynamix or Aramid rope, as the intermediate cover is missing.

Now, a three-quarter fid length of the core is cut off, and the cover brought back to the new core end. A layer of tape seals the end of the rope. The cover now has some slack, which is stroked away from the rope end. Measure two fid lengths from the end of the rope and mark position 1.

Form the eye to the desired size and mark position 2.

Tie a slipknot into the rope about five fid lengths from mark 2.

## 2.

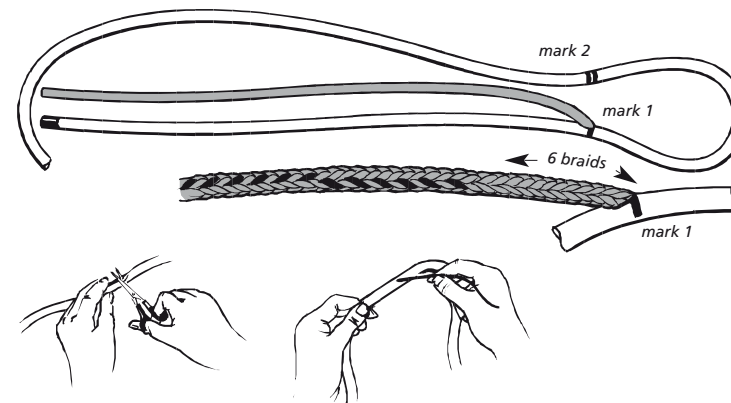

### Precise tapering of the core

At the position marked 1, the core is now pulled out from beneath the cover. This may prove more difficult with a 32 braid. The fid and tip of the pusher are appropriate here, in forming the hole in the cover. Care must be taken, that the core is not disarranged respective to the cover between mark 1 and the slipknot.

It is advisable to fasten the braids at both points with a spike, nail or similar object pushed through them. A layer of tape seals the core end. Now we come to the precise tapering of the core. This step is decisive for the strength, quality and appearance of the splice. Inspect the core braid closely. It will consist either of simple yarns, or twofold, threefold or even fourfold yarns. This braidwork must now be halved over a long section. At this stage, a length of six braids lying next to each other must be measured from mark 1 on the core

(refer to the diagram, where this procedure is outlined clearly). The tapering is to be done from the sixth braid onwards. First taper one braid lay direction i. e., those braids running clockwise. Halve the braids according to the diagram. Where the braid consists only of one yarn, "one over the other" yarn is cut and removed from the braid; with 2 yarns, every other yarn is removed alternatively braid by braid. Where there are three yarns, first two yarns are cut and removed, then from the next group, one yarn is severed and pulled out etc. When all the yarns running in one direction have been halved (e.g. clockwise), then the same procedure is carried out with those yarns running in the other direction – refer to diagram. The tape on the end of the core holds the residual braid together adequately during this procedure.



Ropes with high modulus fibre cores



Eye-Splice, Method 1



Ropes with high modulus fibre cores



Eye-Splice, Method 1

3.

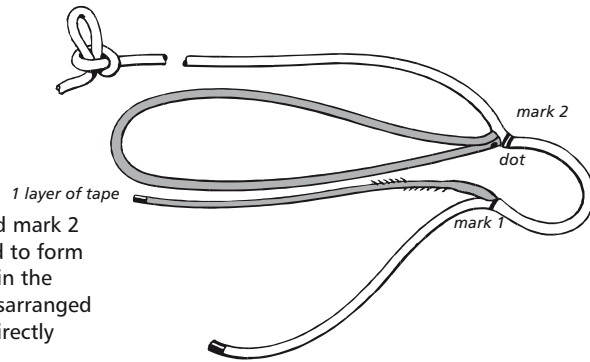

### Making the core loop

The cover is carefully opened behind mark 2 (as in step 2) and the core extracted to form a bight, in such a manner that within the actual eye-sector the cover is not disarranged in respect to the core. Place a dot directly next to mark 2.

5.

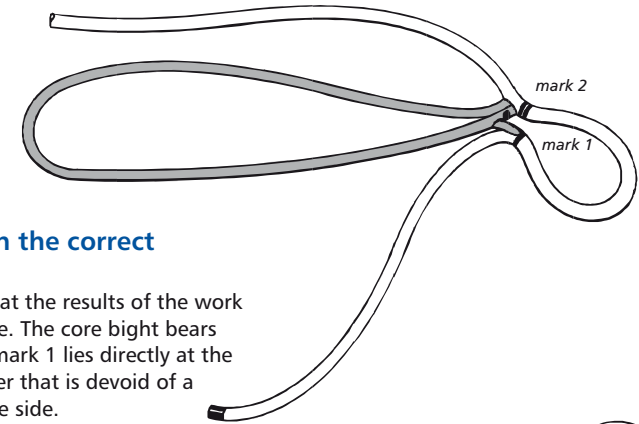

### The core tail lies in the correct splicing position

The diagram shows what the results of the work thus far should look like. The core bight bears the core tail within it. mark 1 lies directly at the dot. The tail of the cover that is devoid of a core hangs limply at the side.

4.

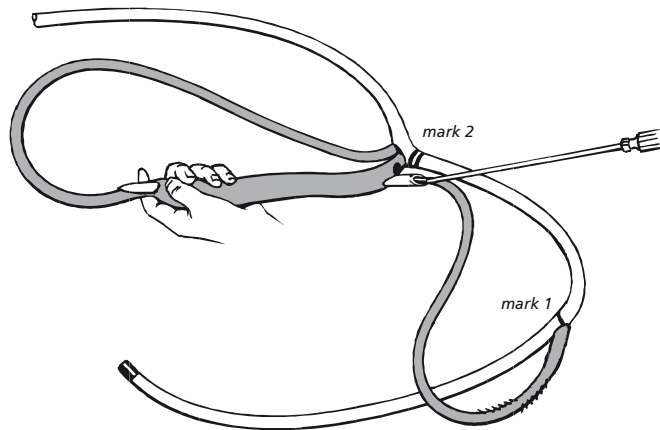

### Splicing the core-end into the core

The fid is inserted at the core bight at the dot. It re-emerges from the bight after two fid lengths, as the core bunches up, the fid emerges from the core whilst at the same time the end of the fid at the dot is still sticking out of the core. The core end is placed into the fid bore and pushed through the core bight with the pusher.

Hold the core end tightly, so that the dot and the core at mark 1 do not become disarranged in relation to each other. Using the other hand, milk the slack and bunched yarns out of the core bight. The core tail thus disappears within the bight.

6.

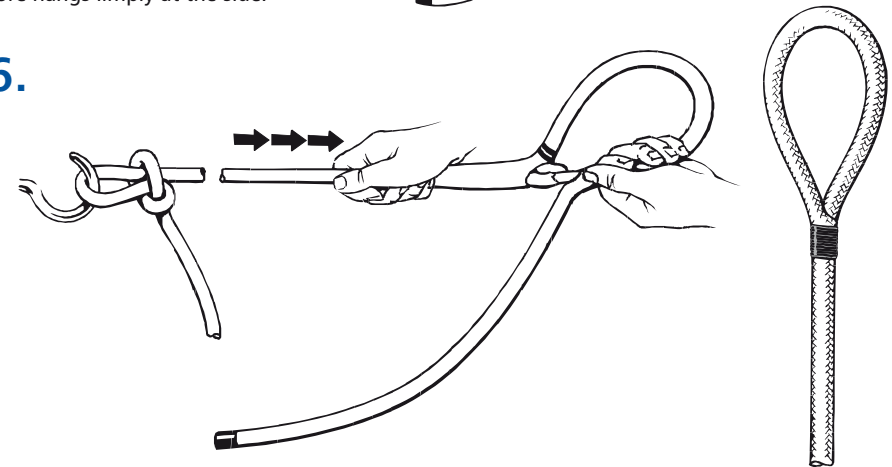

### Milking down of the cover over the core bight

This step may present difficulties to the novice, as the cover is meant to engulf and cover a core bight that in turn contains the core end. The cover can tend to bunch up the core bight. This however can be avoided by keeping constant tension on that section of the rope that is to be milked i.e. the one between the knot and mark 1. When a point is reached where progress becomes difficult, the (incomplete) eye is attached to a hook, the rope itself to a winch and put under tension. This normally does the trick, and the core slips into the cover. Should the procedure however still prove difficult, then

the cover is milked back again and the whole process repeated. To ease the job, the cover can also be beaten soft with the fid or a wooden mallet. Where a thimble is required, it is placed into the eye with the tip at mark 1 shortly prior to the workpiece being drawn together the last time. The final drawing together firmly fixes the thimble in the eye. Now cut off the cover tail about 10 cm behind mark 1, unravel it, then cut back the yarns in a stepped manner and whip these yarns onto the rope. The whipping at the throat of the loop should be sewn through.



Ropes with high modulus fibre cores



Eye-Splice, Method 2



Ropes with high modulus fibre cores



Eye-Splice, Method 2

## Eye-Splice, Method 2

1.

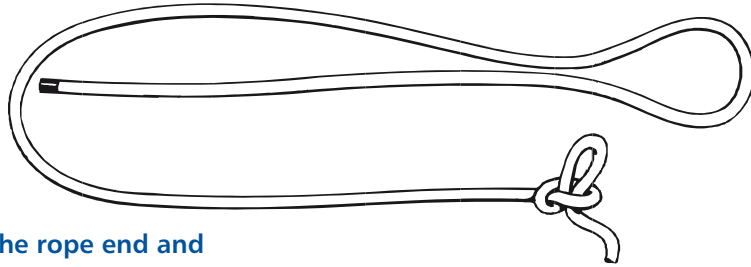

### Preparation of the rope end and removal of the core

The rope end must be taped not heat sealed. Should it have been previously heat sealed, then that section has to be cut off. Remove the tape from the rope end and pull the core out of the cover a distance of about six fid lengths. With our rope types Vectran and Dyneema, a white staple fibre cover is braided around the actual core. This intermediate cover must be removed from the splicing area. This cover is cut right around the six fid length point and removed from the core. Care must be taken that the core

is not damaged in the process. The remaining staple fibre end is then fixed firmly to the core with a thin layer of tape. The cover is then milked back to the end of the rope and fastened loosely by a layer of tape. This step is not required in the case of our Aramid and Dynamix ropes, as they do not have the staple fibre intermediate cover. Tie a slipknot into the rope at a distance of six fid lengths.

2.

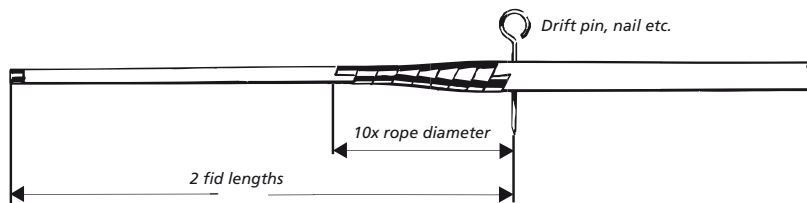

### Shortening of the cover and fastening of the end of the cover

The cover is severed one fid length from the end and removed. Care must be taken that the core is not damaged during this process. The cover is positioned relative to the core in the following manner: a sharp instrument such as an awl, nail, thin fid, pusher etc. is stuck through the rope two fid lengths from its end, this is point "A". In front of point "A", the tail of the cover remains for the length "X". "X" = 10 times the

diameter of the rope. The distance "X" is unravelled for three-quarters of its length and tapered. This is done by cutting away half of the braided yarns progressively in steps. Beginning at "A", the cover tail has tape wound around it until it is securely fastened to the core. NB.: Make sure that only one layer of tape is wound around so that the rope section is not too thick.

3.

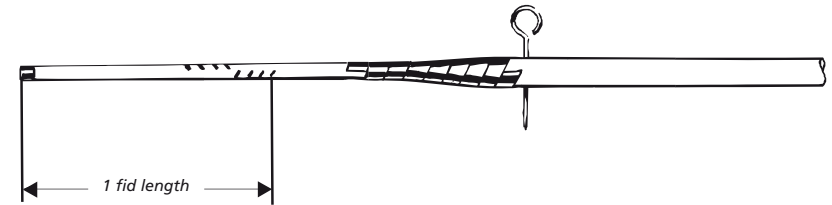

### Precise tapering of the core end

A layer of tape is bound around the core end. This is the beginning of the tapering of the core tail, an important step for the strength, quality and appearance of the splice. Upon closer inspection of the core, it will be seen that the braid consists of either single yarns, or twofold, threefold, or even fourfold yarns. This braiding must be halved over a relatively long section. Measure one fid length from the core end. The tapering is carried out from this length onwards. Start by tapering one braid direction first, those running in a clockwise direction for example. Halve the braids according to the

diagram. Where the braid consists of single yarns, "one over the other" yarn is cut and removed alternatively. Where the braid consists of two parallel yarns, one of these is cut and removed, braid by braid. In the case of 3 yarns, first two yarns are cut and removed, then from the next group, one yarn only etc. When all the yarns running in one direction have been halved (i.e. clockwise), then repeat this procedure with those running in the opposite direction. Refer to the diagram.

4.

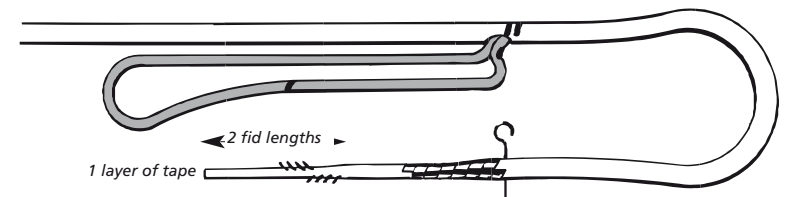

### Measurement of the eye and extraction of a bight of the core

The eye is formed to the desired size directly behind "A" and point "B" marked. Point "B" can be fastened with a layer of tape, as during the following steps, the eye section must not suffer displacement between core and cover. It is a good idea at this stage, to use a pin or a nail pushed through the rope to secure the relative positions of the core and the cover. The cover braid is opened at "B". This can be somewhat difficult at first. Bend the rope sharply, ease the

yarns apart with the aid of a tool such as a pusher, fid etc. until an opening has been made in the cover braid, and pull out a section of the core in a bight or loop (see the diagram). Note: To be able to loosen the yarns sufficiently to allow an opening to be made in the braid, the tip of the fid is pushed under the yarns, the fid is then turned around (rotated) so that yarns curl up, thereby creating sufficient slack to enable a hole to be made.



Ropes with high modulus fibre cores



Eye-Splice, Method 2

5.

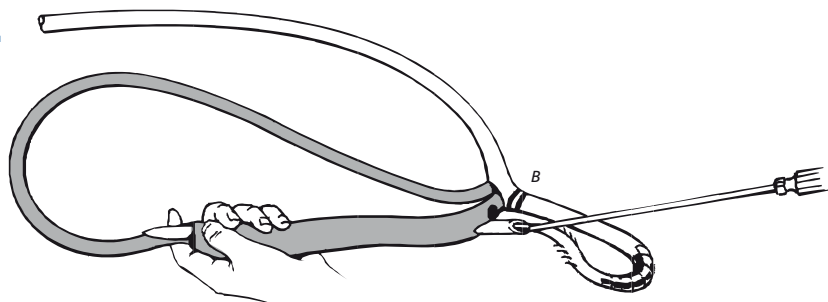

### Splicing the core tail into the core

The fid is introduced into the bight of the core directly behind point "B". It re-emerges from the bight after two fid lengths. As the core bunches up, the fid emerges from the core, whilst at the same time the end of the fid still sticks out of the core at "B". The core end is

now placed into the fid bore and pushed through the core bight by the pusher until the whole tapered core and cover end disappear inside the bight. The core bight is then milked smooth.

6.

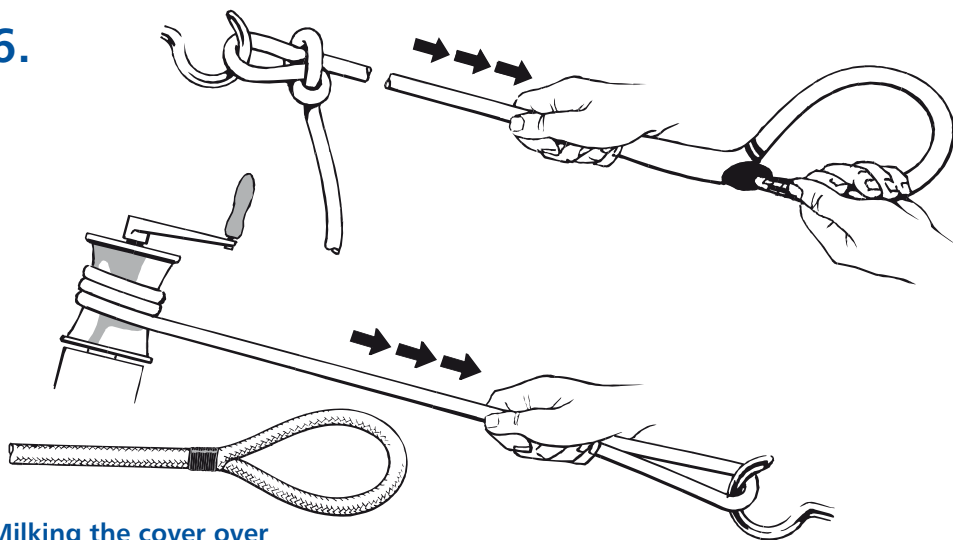

### Milking the cover over the bight of the core

Attaching the slipknot to a hook, milk the slack of the cover over the core bight. This is relatively easy at first, but becomes progressively more difficult due to the core having to accommodate the end of the rope, thereby becoming much thicker and causing the cover to resist. The core bight then has a tendency to bunch up. Attach the (incomplete) eye to a hook,

place the rope around a winch and pull the remainder of the core bight forcefully into the rope. If a thimble needs to be spliced into the eye, it is placed into the eye shortly before everything is drawn together for the last time. The thimble is positioned such that its tip points to point "B". The final pulling together fixes the thimble firmly in the eye.



## Whipping and Seizing



### Construction and Applications

Whippings are used to prevent rope ends from opening up and fraying and to add extra protection to a spliced rope. Before a newly spliced rope is put into use, and before the newly aligned yarns have bedded in under load, it is sometimes possible to pull out a spliced end. A secure whipping or seizing will prevent this. A secure whipping can prove a better solution than heat sealing or cutting and taping a rope end, as tape can be destroyed by salt water and a heat sealed rope end can separate between the melted and intact fibres. We show only two of the many types of whipping or seizing.



## Simple Whipping

Whipping secures the end of a rope. It is superior to heat sealing of a man-made fibre rope, as the rope end is compressed in diameter and does not bulge at the end as with heat sealed ropes. The whipping is best carried out with waxed whipping twine of a thickness appropriate to the diameter of the rope (an essential item in any rigging kit).

1.

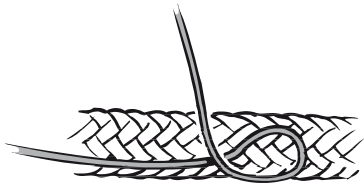

The whipping is best applied about 5 cm from the end of the rope. The whipping twine forms a loop placed on the rope in the direction of the rope end, as the diagram shows. Hold the loop in place and wind the whipping twine tightly and uniformly, with constant hand tension, towards the end of the rope around both the rope and the twine loop.

2.

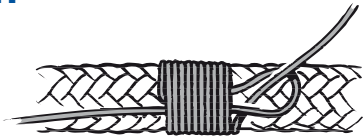

The wound whipping ends about two cm from the end of the rope. The whipping twine end is then put through the small loop sticking out at the end – see diagram.

3.



Pull on the left piece of whipping twine (as shown in the diagram). The loop is drawn tight and holds the whipping twine fast in its bight; it furthermore pulls the loop under the whipping, when the loop end has reached more or less the middle underneath the whipping, both loose ends of the whipping twine are cut off close to the rope and the whipping is complete.



## Sewn Whipping

1.

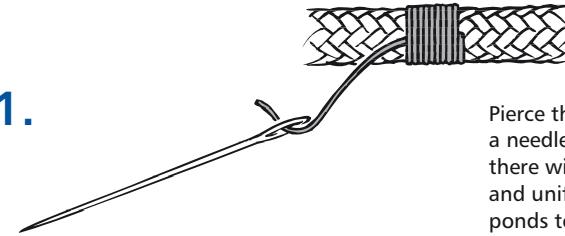

Pierce the rope about 1–2 cm from its end with a needle and fix the whipping twine tightly there with two stitches. Wind the twine tightly and uniformly for one whipping which corresponds to approximately one rope diameter. Using the needle pull the end of the whipping twine underneath the wound whipping.

2.

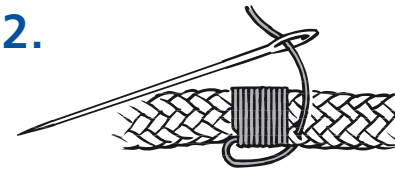

The twine is sewn over the whipping and then directly behind it, sewn through the braid.

3.

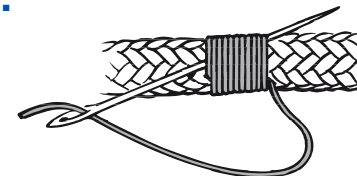

Rotate the rope through 180°, sew the whipping twine through underneath the whipping, parallel to the twine sewn over the whipping. Repeat this procedure once more

4.



Now the whipping has been sewn fast three times by a yarn. Sew one more parallel yarn over the whipping by sewing through the rope. The diagram shows what the whipping looks like when it has been completed. **Note:** with braided ropes, the whipping twine runs parallel to the lay of the braid.

**Geo. Gleistein & Sohn GmbH**

Heidlerchenstraße 7  
28777 Bremen  
Germany

**Phone**

Sales department: +49 421 69049-49

Purchase department: +49 421 69049-59

Technical department: +49 421 69049-69

**Fax:** +49 421 69049-99

**E-Mail:** info@gleistein.com

**[www.gleistein.com](http://www.gleistein.com)**