

## Assembly instruction



### Tools Required:

Saw  
Drill  
Ø 6.5 mm drill bit  
Screwdriver torx  
Hammer  
Pop Rivet Gun

### Parts included in kit

Extrusion with outboard end fitted  
Inboard end  
Fasteners  
Pad eyes (screw M6 not incl.)

### Assembly

1. Find the correct length, see table 2 (DBS + USL). When in doubt, contact dealer.
2. Mark the length of the extrusion, see table 1 for reductions. (Use a paper as a guide as fig. 1). Cut the extrusion.
3. Mark the holes for the rivets, according to table 1.
4. Drill the holes with a Ø 6.5 mm drill bit.
5. Fit the inboard end with pop-rivets and punch out the mandrel heads.

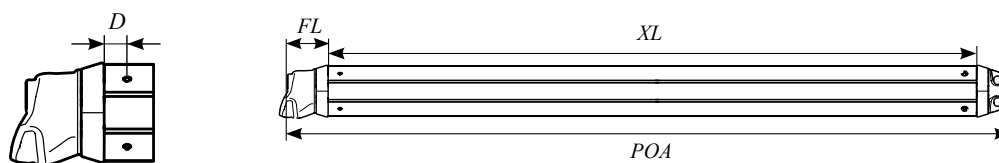
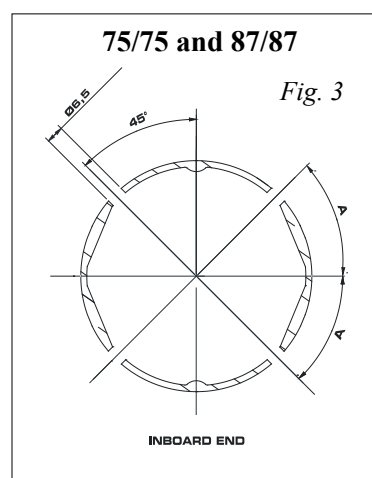
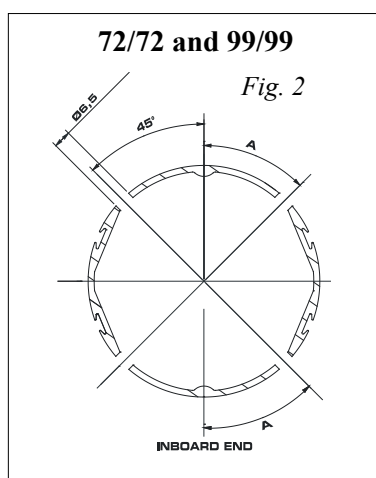
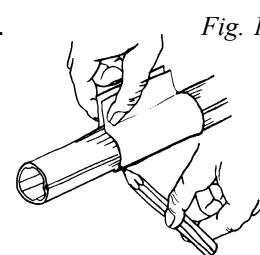

Bowsprit size	A	D	Extrusion length
G072	29	40	XL = POA - 78
G075	30	40	XL = POA - 78
G087	34	20	XL = POA - 122
G099	39	20	XL = POA - 158
G120	47	25	XL = POA - 63

Tab. 1